

Simulink® PLC Coder™

User's Guide

R2012b

**MATLAB®
& SIMULINK®**

How to Contact MathWorks



www.mathworks.com Web
comp.soft-sys.matlab Newsgroup
www.mathworks.com/contact_TS.html Technical Support



suggest@mathworks.com Product enhancement suggestions
bugs@mathworks.com Bug reports
doc@mathworks.com Documentation error reports
service@mathworks.com Order status, license renewals, passcodes
info@mathworks.com Sales, pricing, and general information



508-647-7000 (Phone)



508-647-7001 (Fax)



The MathWorks, Inc.
3 Apple Hill Drive
Natick, MA 01760-2098

For contact information about worldwide offices, see the MathWorks Web site.

Simulink® PLC Coder™ User's Guide

© COPYRIGHT 2010–2012 by The MathWorks, Inc.

The software described in this document is furnished under a license agreement. The software may be used or copied only under the terms of the license agreement. No part of this manual may be photocopied or reproduced in any form without prior written consent from The MathWorks, Inc.

FEDERAL ACQUISITION: This provision applies to all acquisitions of the Program and Documentation by, for, or through the federal government of the United States. By accepting delivery of the Program or Documentation, the government hereby agrees that this software or documentation qualifies as commercial computer software or commercial computer software documentation as such terms are used or defined in FAR 12.212, DFARS Part 227.72, and DFARS 252.227-7014. Accordingly, the terms and conditions of this Agreement and only those rights specified in this Agreement, shall pertain to and govern the use, modification, reproduction, release, performance, display, and disclosure of the Program and Documentation by the federal government (or other entity acquiring for or through the federal government) and shall supersede any conflicting contractual terms or conditions. If this License fails to meet the government's needs or is inconsistent in any respect with federal procurement law, the government agrees to return the Program and Documentation, unused, to The MathWorks, Inc.

Trademarks

MATLAB and Simulink are registered trademarks of The MathWorks, Inc. See www.mathworks.com/trademarks for a list of additional trademarks. Other product or brand names may be trademarks or registered trademarks of their respective holders.

Patents

MathWorks products are protected by one or more U.S. patents. Please see www.mathworks.com/patents for more information.

Revision History

March 2010 Online only
September 2010 Online only
April 2011 Online only
September 2011 Online only
March 2012 Online only
September 2012 Online only

New for Version 1.0 (Release 2010a)
Revised for Version 1.1 (Release 2010b)
Revised for Version 1.2 (Release 2011a)
Revised for Version 1.2.1 (Release 2011b)
Revised for Version 1.3 (Release 2012a)
Revised for Version 1.4 (Release 2012b)

Getting Started

1

Product Description	1-2
Key Features	1-2
PLC Code Generation in the Development Process ...	1-3
Expected Users	1-3
Glossary	1-4
System Requirements	1-4
Related Products	1-5
Supported Simulink and Stateflow Blocks	1-6
Supported IDE Platforms	1-7
3S-Smart Software Solutions CoDeSys Software	1-8
B&R Automation Studio 3.0 Software	1-8
Beckhoff TwinCAT 2.11	1-8
KW-Software MULTIPROG 5.0	1-8
Phoenix Contact PC WORX Version 6.0	1-9
Rockwell Automation RSLogix 5000 Software	1-9
Siemens SIMATIC STEP 7	1-9
PLC Code Generation Workflow	1-10
Prepare Model for Structured Text Generation	1-11
Solvers	1-11
Configuring Simulink Models for Structured Text Code Generation	1-11
Checking System Compatibility for Structured Text Code Generation	1-16
Generate and Examine Structured Text Code	1-19
Generate Structured Text from the Model Window	1-19

Generate Structured Text with the MATLAB Interface ...	1-24
Generate Structured Text Code and Integrate with Existing Siemens SIMATIC STEP 7 Projects	1-25
Matrix Data Types	1-26
Generated Code Header	1-26
Specify Custom Names for Generated Files	1-26
Propagation of Block Descriptions	1-27
Internal Signals for Debugging in RSLogix 5000 IDE	1-28
Import Structured Text Code Automatically	1-31
PLC IDEs That Qualify for Importing Code Automatically	1-31
Generate and Automatically Import Structured Text Code	1-32
Troubleshoot Automatic Import Issues	1-33
Integrate Absolute Time Temporal Logic Code	1-35
Simulation and Code Generation of Motion	
Instructions	1-38
Workflow for Using Motion Instructions in Model	1-38
Library of Motion Instructions	1-41
Data Types for Motion Instructions	1-41
Limitations for MAM Instruction	1-42

Mapping Simulink Semantics to Structured Text

2

Simulink PLC Coder Mapping Semantics	2-2
Generated Code Structure for Simple Simulink Subsystems	2-3
Generated Code Structure for Reusable Subsystems ..	2-5
Generated Code Structure for Triggered Subsystems ..	2-7

Generated Code Structure for Stateflow Charts	2-9
Generated Code Structure for MATLAB Function Block	2-11

Generating Test Bench Code

3

Generated Structured Text and Test Bench Code	3-2
Test Bench Verification	3-2
Generated Files	3-2
Integrate Generated Code into Custom Code	3-2
 Generate and Manually Import Test Bench Code	 3-5
 Import and Verify Structured Text Code	
Automatically	3-9
Import and Verify Structured Text to KW-Software MULTIPROG 5.0 and Phoenix Contact PC WORX 6.0 IDEs Automatically	3-9
Generate, Automatically Import, and Verify Structured Text	3-11

Code Generation Reports

4

Information in Code Generation Reports	4-2
 Create and Use Code Generation Reports	 4-4
Generate a Traceability Report from Configuration Parameters	4-4
Keep the Report Current	4-6
Trace from Code to Model	4-7
Trace from Model to Code	4-8
Model Web View in Code Generation Report	4-10

Working with Tunable Parameters in the Simulink PLC Coder Environment

5

Configure Tunable Parameters for Your Model	5-2
Tunable Parameters	5-2
Configure Your Model for Tunable Parameters	5-5
Identify Tunable Parameters	5-8
Tune Parameters Using Simulink.Parameter	
Objects	5-12
Work Directly with Simulink.Parameter Objects	5-12
Work with Simulink.Parameter Objects Using Model Explorer	5-15
Configure Tunable Parameters Using Configuration Parameters	5-17
Defining Tunable Parameter Values in the MATLAB Workspace	5-17
Configuring Parameters to Be Tunable	5-19

Controlling Generated Code Partitions

6

Function Block Partitions	6-2
Function Block Partitioning Guidelines	6-2
One Function Block for Atomic Subsystems	6-2
One Function Block for Virtual Subsystems	6-3
Multiple Function Blocks for Nonvirtual Subsystems	6-4
Control Generated Code Using Subsystem Block Parameters	6-5

Integrating Externally Defined Symbols

7

Integrate Externally Defined Symbols	7-2
Integrate Custom Function Block in Generated Code	7-3

IDE-Specific Considerations

8

Rockwell Automation RSLogix Considerations	8-2
Add-On Instruction and Function Blocks	8-2
Double-Precision Data Types	8-2
Unsigned Integer Data Types	8-2
Unsigned Fixed-Point Data Types	8-3
Enumerated Data Types	8-3
Siemens SIMATIC STEP 7 Considerations	8-4
Double-Precision Floating-Point Data Types	8-4
int8 and Unsigned Integer Types	8-4
Unsigned Fixed-Point Data Types	8-4
Enumerated Data Types	8-5

Supported Simulink and Stateflow Blocks

9

Simulink Blocks	9-2
Stateflow Blocks	9-12

10

Coder Limitations	10-2
Current Limitations	10-2
Fixed-Point Data Type Limitations	10-3
Permanent Limitations	10-5
Block Restrictions	10-6
Simulink Block Support Exceptions	10-6
Stateflow Chart Exceptions	10-6
Reciprocal Sqrt Block	10-7
Lookup Table Blocks	10-7

Functions — Alphabetical List

11

Configuration Parameters for Simulink PLC
Coder Models

12

PLC Coder: General	12-2
PLC Coder: General Tab Overview	12-3
Target IDE	12-4
Target IDE Path	12-6
Code Output Directory	12-8
Generate testbench for subsystem	12-9
PLC Coder: Comments	12-10
Comments Overview	12-11
Include comments	12-11
Include block description	12-12
Simulink block / Stateflow object comments	12-13
Show eliminated blocks	12-14

PLC Coder: Optimization	12-15
Optimization Overview	12-15
Signal storage reuse	12-16
Remove code from floating-point to integer conversions that wraps out-of-range values	12-18
Loop unrolling threshold	12-19
PLC Coder: Symbols	12-20
Symbols Overview	12-21
Maximum identifier length	12-22
Use the same reserved names as Simulation Target	12-23
Reserved names	12-24
Externally Defined Symbols	12-25
PLC Coder: Report	12-26
Generate traceability report	12-26
Generate model Web view	12-27

Index



Getting Started

- “Product Description” on page 1-2
- “PLC Code Generation in the Development Process” on page 1-3
- “Related Products” on page 1-5
- “Supported Simulink and Stateflow Blocks” on page 1-6
- “Supported IDE Platforms” on page 1-7
- “PLC Code Generation Workflow” on page 1-10
- “Prepare Model for Structured Text Generation” on page 1-11
- “Generate and Examine Structured Text Code” on page 1-19
- “Import Structured Text Code Automatically” on page 1-31
- “Integrate Absolute Time Temporal Logic Code” on page 1-35
- “Simulation and Code Generation of Motion Instructions” on page 1-38

Product Description

Generate IEC 61131 structured text for PLCs and PACs

Simulink® PLC Coder™ generates hardware-independent IEC 61131 structured text from Simulink models, Stateflow® charts, and Embedded MATLAB® functions. The structured text is generated in PLCopen and other file formats supported by widely used integrated development environments (IDEs). As a result, you can compile and deploy your application to numerous programmable logic controller (PLC) and programmable automation controller (PAC) devices.

Simulink PLC Coder generates test benches that help you verify the structured text using PLC and PAC IDEs and simulation tools. Support for industry standards is available through IEC Certification Kit (for IEC 61508 and IEC 61511).

Key Features

- Automatic generation of IEC 61131-3 structured text
- Simulink support, including reusable subsystems, PID controller blocks, and lookup tables
- Stateflow support, including graphical functions, truth tables, and state machines
- Embedded MATLAB support, including if-else statements, loop constructs, and math operations
- Support for multiple data types, including Boolean, integer, enumerated, and floating-point, as well as vectors, matrices, buses, and tunable parameters
- IDE support, including B&R Automation Studio®, PLCopen, Rockwell Automation® RSLogix™ 5000, Siemens® SIMATIC® STEP® 7, and Smart Software Solutions CoDeSys
- Test-bench creation

PLC Code Generation in the Development Process

Simulink PLC Coder software lets you generate IEC-61131-3 compliant structured text code from Simulink models. This software brings the Model-Based Design approach into the domain of PLC and PAC development. Using the coder, system architects and designers can spend more time fine-tuning algorithms and models through rapid prototyping and experimentation, and less time on coding PLCs.

Typically, you use a Simulink model to simulate a design for realization in a PLC. Once satisfied that the model meets design requirements, run the Simulink PLC Coder compatibility checker utility. This utility verifies compliance of model semantics and blocks for PLC target IDE code generation compatibility. Next, invoke the Simulink PLC Coder tool, using either the command line or the graphical user interface. The coder generates structured text code that implements the design embodied in the model.

Usually, you also generate a corresponding test bench. You can use the test bench with PLC emulator tools to drive the generated structured text code and evaluate its behavior.

The test bench feature increases confidence in the generated code and saves time spent on test bench implementation. The design and test process are fully iterative. At any point, you can return to the original model, modify it, and regenerate code.

At completion of the design and test phase of the project, you can easily export the generated Structure Text code to your PLC development environment. You can then deploy the code.

Expected Users

The Simulink PLC Coder product is a tool for control and algorithm design and test engineers in the following applications:

- PLC manufacturing
- Machine manufacturing
- Systems integration

You should be familiar with:

- MATLAB® and Simulink software and concepts
- PLCs
- Structured text language

If you want to download generated code to a PLC IDE, you should also be familiar with your chosen PLC IDE platform. See “Supported IDE Platforms” on page 1-7 for a list of these platforms.

Glossary

Term	Definition
PAC	Programmable automation controller.
PLC	Programmable logic controller.
IEC 61131-3	IEC standard that defines PLC coder languages, including the structured text language for which the Simulink PLC Coder software generates code.
PLCopen	Vendor- and product-independent organization that works with the IEC 61131-3 standard. The Simulink PLC Coder product can generate structured text using the PLCopen XML standard format. See http://www.plcopen.org/pages/tc6_xml/xml_intro/index.htm for details.
structured text	High-level textual language defined by IEC-61131-3 standard for the programming of PLCs.
function block	Structured text language programming concept that allows the encapsulation and reuse of algorithmic functionality.

System Requirements

See the MathWorks Web site at System Requirements for a list of related products.

Related Products

See the MathWorks Web site at Related Products for a list of related products.

Supported Simulink and Stateflow Blocks

To access a Simulink library of blocks that the Simulink PLC Coder software supports, type `plclib` in the MATLAB Command Window. The coder can generate structured text code for subsystems that contain these blocks. The library window is displayed.

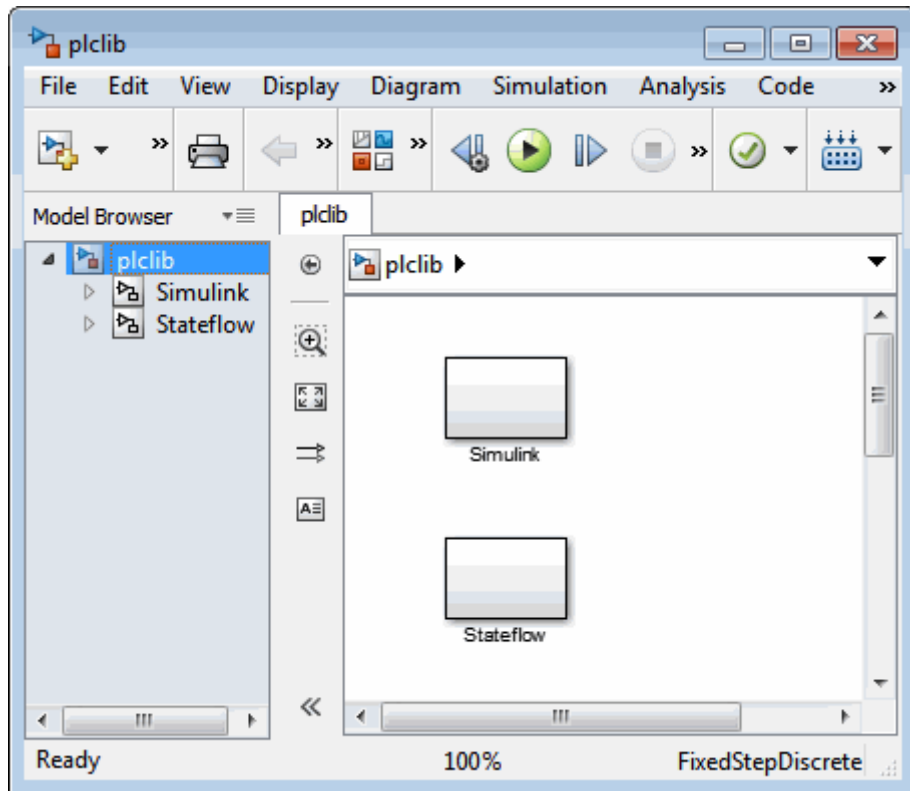

This library contains two sublibraries, Simulink and Stateflow. Each sublibrary contains the blocks that you can include in a Simulink PLC Coder model.

For a list of the supported blocks, see “Simulink Blocks” on page 9-2 and “Stateflow Blocks” on page 9-12. See “Block Restrictions” on page 10-6 for restrictions on using these blocks.

Supported IDE Platforms

The Simulink PLC Coder product supports the following IDE platforms:

- 3S-Smart Software Solutions CoDeSys Version 2.3 or 3.3
- B&R Automation Studio 3.0
- Beckhoff® TwinCAT® 2.11
- KW-Software MULTIPROG® 5.0

Note The Simulink PLC Coder software supports only the English version of KW-Software MULTIPROG target IDE.

- Phoenix Contact® PC WORX™ 6.0

Note The Simulink PLC Coder software supports only the English version of Phoenix Contact PC WORX target IDE.

- Rockwell Automation RSLogix 5000 Series Version 17, 18, or 19

Note The Simulink PLC Coder software can generate code for Add-On instructions (AOIs) and routine code.

- Siemens SIMATIC STEP 7 Version 5.4

Note The Simulink PLC Coder software assumes that:

- English systems use English S7
 - German systems use German S7
-

- Generic

- PLCOpen XML

See the MathWorks Web site at Supported IDEs for a list of supported IDEs and platforms.

3S-Smart Software Solutions CoDeSys Software

To get CoDeSys Version 2.3 or 3.3, see:

http://www.3s-software.com/index.shtml?en_download

This download page requires you to be a registered user.

- 1** If you are not yet a registered user, create an account. It might take a few days to receive a password for the account.
- 2** When you receive a password, use it to access the download page.
- 3** On the download page, select the CoDeSys software to download.

You do not need to download the CoDeSys SP RTE example.

- 4** Follow CoDeSys download and installation instructions to install the software.

B&R Automation Studio 3.0 Software

To get the B&R Automation Studio product, see:

http://www.br-automation.com/cps/rde/xchg/br-productcatalogue-/hs.xsl/cookies_allowed.htm?caller=products_5309_ENG_HTML.htm/

Beckhoff TwinCAT 2.11

To get the Beckhoff TwinCAT 2.11 product, see:

<http://www.beckhoff.com/english.asp?twincat/default.htm>

KW-Software MULTIPROG 5.0

To get the KW-Software MULTIPROG 5.0 product, see:

<http://www.kw-software.com/com/index1024.html>

Phoenix Contact PC WORX Version 6.0

To get the Phoenix Contact PC WORX Version 6.0 product, see:

http://www.phoenixcontact.com/automation/32131_31906.htm

Rockwell Automation RSLogix 5000 Software

To get the Rockwell Automation RSLogix 5000 product, see:

<http://www.rockwellautomation.com/rockwellsoftware/design/-rslogix5000/>

The coder can generate code for Rockwell Automation RSLogix 5000 Add-On instructions (AOIs) and routines.

Siemens SIMATIC STEP 7

To get the Siemens SIMATIC STEP 7 Version 5.4 product, see:

<http://www.sea.siemens.com/us/Products/Automation/-Engineering-Software/step-7-pro/Pages/step-7-pro.aspx>.

PLC Code Generation Workflow

The basic workflow of Simulink PLC Coder users includes:

- 1** Define and design a Simulink model from which you want to generate code.
- 2** Identify the model components for which you want to generate code for importing to a PLC.
- 3** Place the components in a Subsystem block.
- 4** Identify your target PLC IDE.
- 5** Select a solver.
- 6** Configure the Subsystem block to be atomic.
- 7** Check that the model is compatible with the Simulink PLC Coder software.
- 8** Simulate your model.
- 9** Configure model parameters to generate code for your PLC IDE.
- 10** Examine the generated code.
- 11** Import code to your PLC IDE.

Prepare Model for Structured Text Generation

In this section...

“Solvers” on page 1-11

“Configuring Simulink Models for Structured Text Code Generation” on page 1-11

“Checking System Compatibility for Structured Text Code Generation” on page 1-16

Solvers

Choose a solver for your Simulink PLC Coder model.

Model	Solver Setting
Continuous	Use a continuous solver and configure a fixed sample time for the subsystem for which you generate code.
Discrete	Discrete fixed-step solver.

Configuring Simulink Models for Structured Text Code Generation

This topic assumes that you have a model for which you want to generate and import code to a PLC IDE. Before you use this model, perform the following steps.

- 1 In the MATLAB Command Window, open your model. For example:

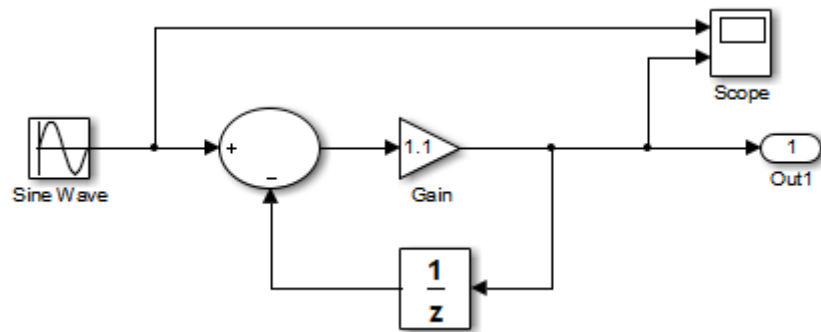

- 2 Configure the model to use the fixed-step discrete solver. To do this, select **Simulation > Model Configuration Parameters** and in the Solver pane, set **Type** to Fixed-step and **Solver** to discrete (no continuous states).

If your model uses a continuous solver, has a subsystem, configure a fixed sample time for the subsystem for which you generate code.

- 3 Save this model as `plcdemo_simple_subsystem1`.
- 4 Place the components for which you want to generate structured text code in a subsystem. For example:

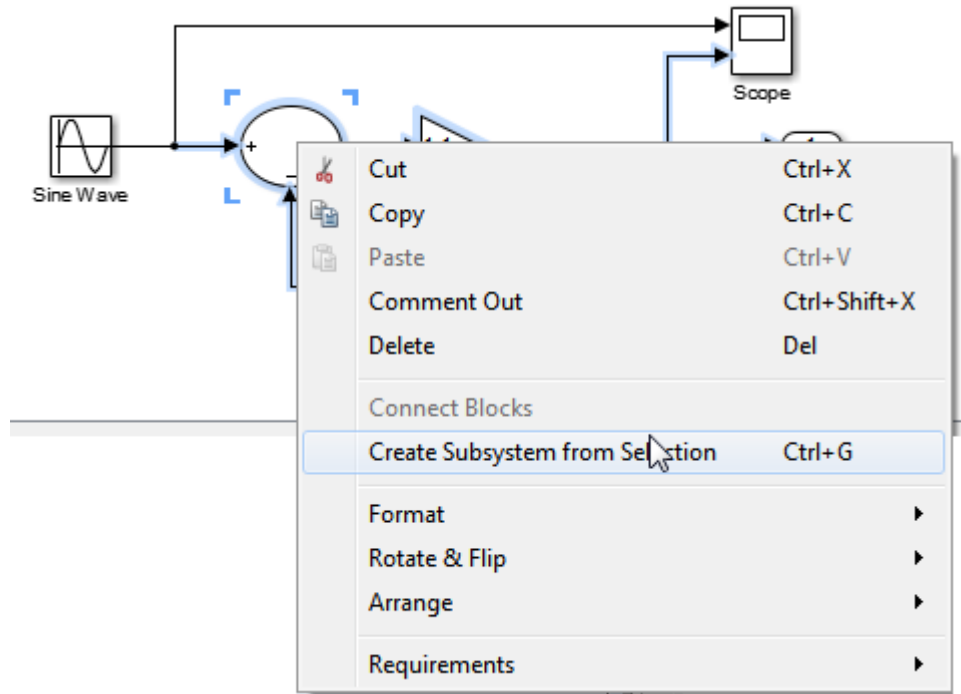

Optionally, rename In1 and Out1 to U and Y respectively. This operation results in a subsystem like the following:

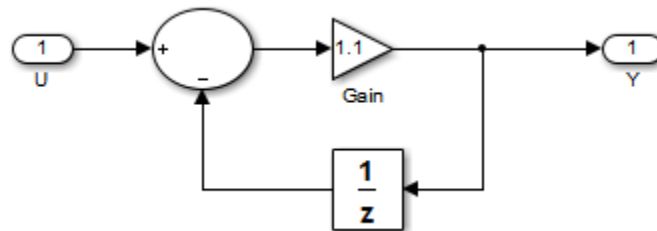

- 5 Save the subsystem.
- 6 In the top-level model, right-click the Subsystem block and select **Block Parameters (Subsystem)**.

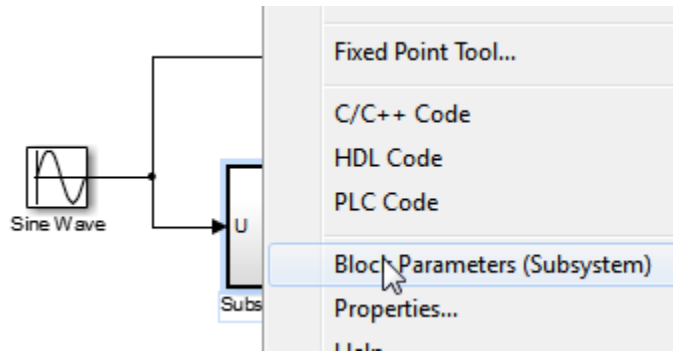

7 In the resulting block dialog box, select **Treat as atomic unit**.

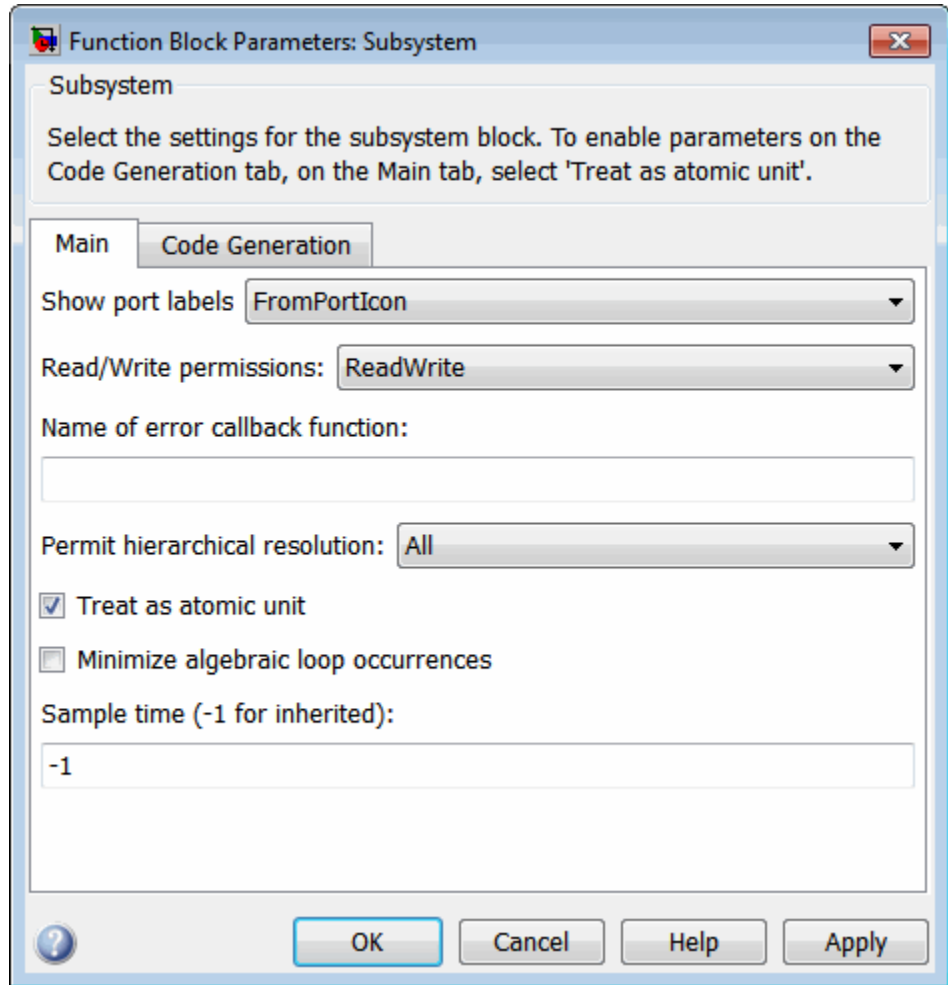

- 8** Click **OK**.
- 9** Simulate your model.
- 10** Save your model. In later procedures, you can use either this model, or the `plcdemo_simple_subsystem` model that comes with your software.

You are now ready to:

- Set up your subsystem to generate structured text code. See “Checking System Compatibility for Structured Text Code Generation” on page 1-16.
- Generate structured text code for your IDE. See “Generate and Examine Structured Text Code” on page 1-19.

Checking System Compatibility for Structured Text Code Generation

This topic assumes that you have a model that you have configured to work with the Simulink PLC Coder software.

- 1 In your model, navigate to the subsystem for which you want to generate code.
- 2 Right-click that Subsystem block and select **PLC Code > Check Subsystem Compatibility**.

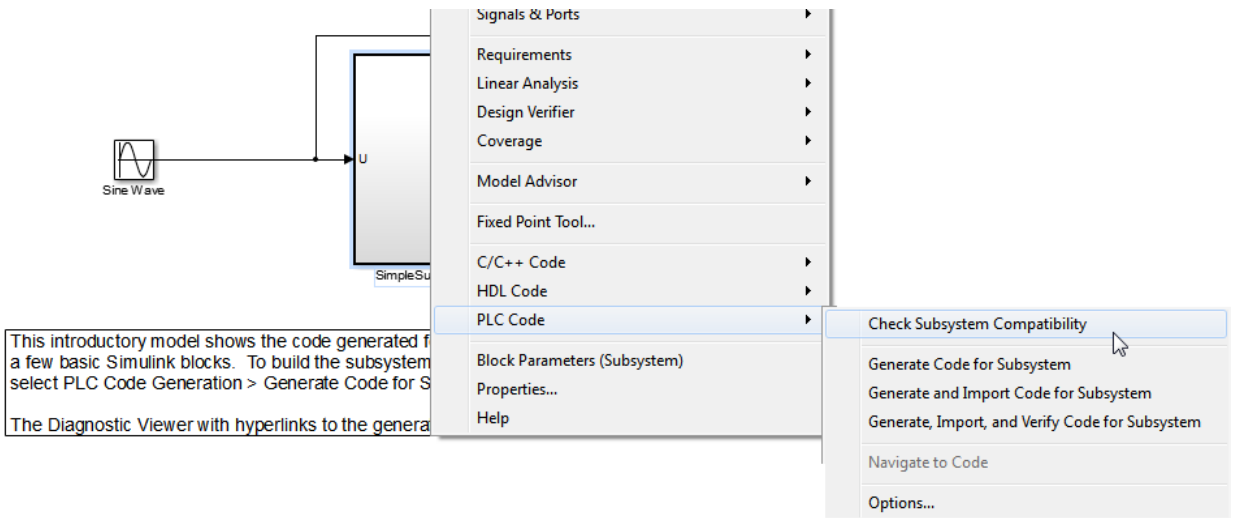

The coder verifies that your model satisfies the Simulink PLC Coder criteria and displays an information window when done.

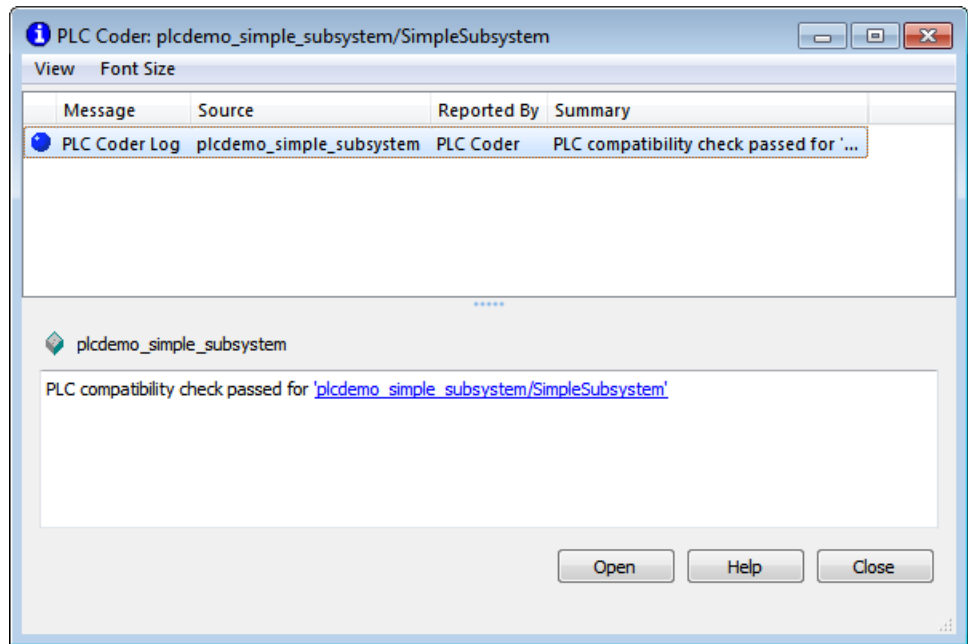

If the subsystem is not atomic, right-clicking the Subsystem block and selecting **PLC Code** prompts you to select **Enable “Treat as atomic unit” to generate code**.

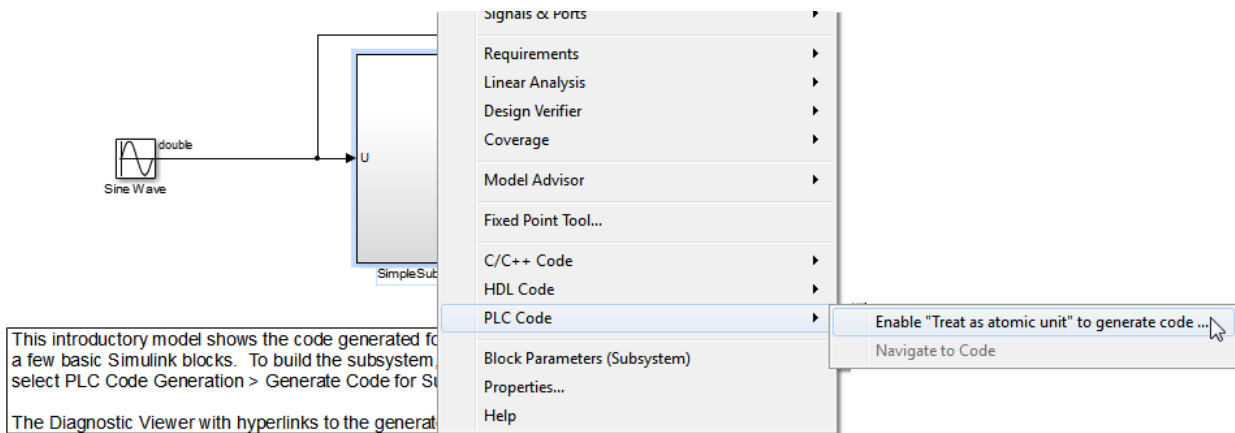

This command opens the block parameter dialog box so that you can select the **Treat as atomic unit** check box.

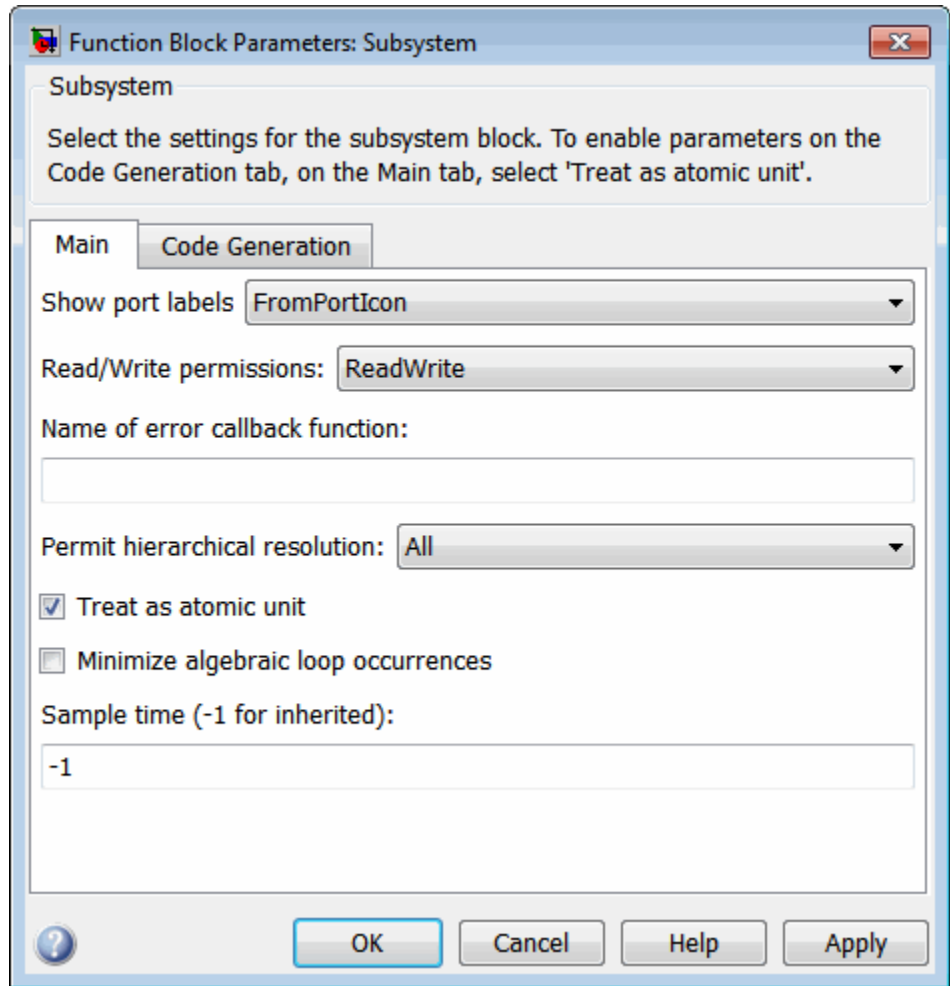

You are now ready to generate structured text code for your IDE. See “Generate and Examine Structured Text Code” on page 1-19.

Generate and Examine Structured Text Code

In this section...

“Generate Structured Text from the Model Window” on page 1-19

“Generate Structured Text with the MATLAB Interface” on page 1-24

“Generate Structured Text Code and Integrate with Existing Siemens SIMATIC STEP 7 Projects” on page 1-25

“Matrix Data Types” on page 1-26

“Generated Code Header” on page 1-26

“Specify Custom Names for Generated Files” on page 1-26

“Propagation of Block Descriptions” on page 1-27

“Internal Signals for Debugging in RSLogix 5000 IDE” on page 1-28

Generate Structured Text from the Model Window

This topic assumes that you have set up your environment and Simulink model to use the Simulink PLC Coder software to generate structured text code. If you have not yet done so, see “Prepare Model for Structured Text Generation” on page 1-11.

- 1 If you do not have the `plcdemo_simple_subsystem` model open, open it now.
- 2 Right-click the Subsystem block and select **PLC Code > Options**.

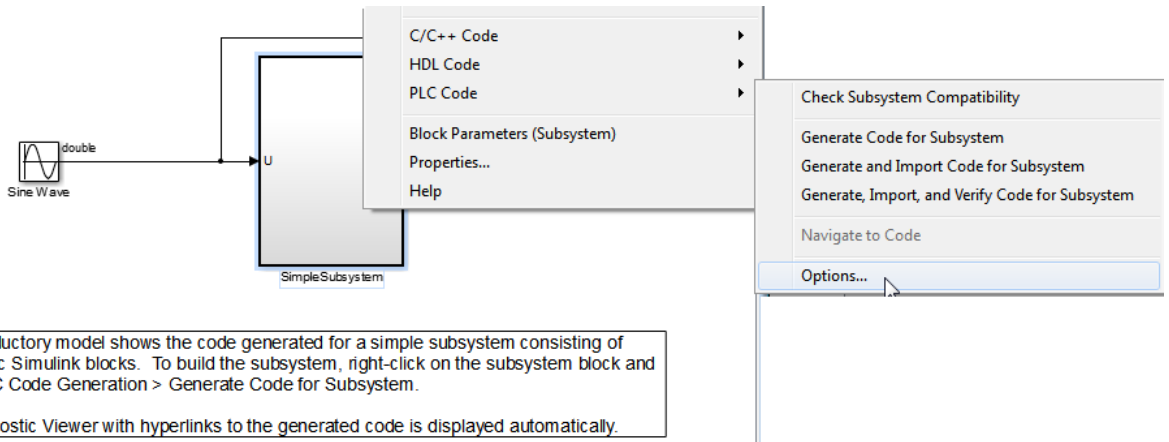

The Configuration Parameters dialog box is displayed.

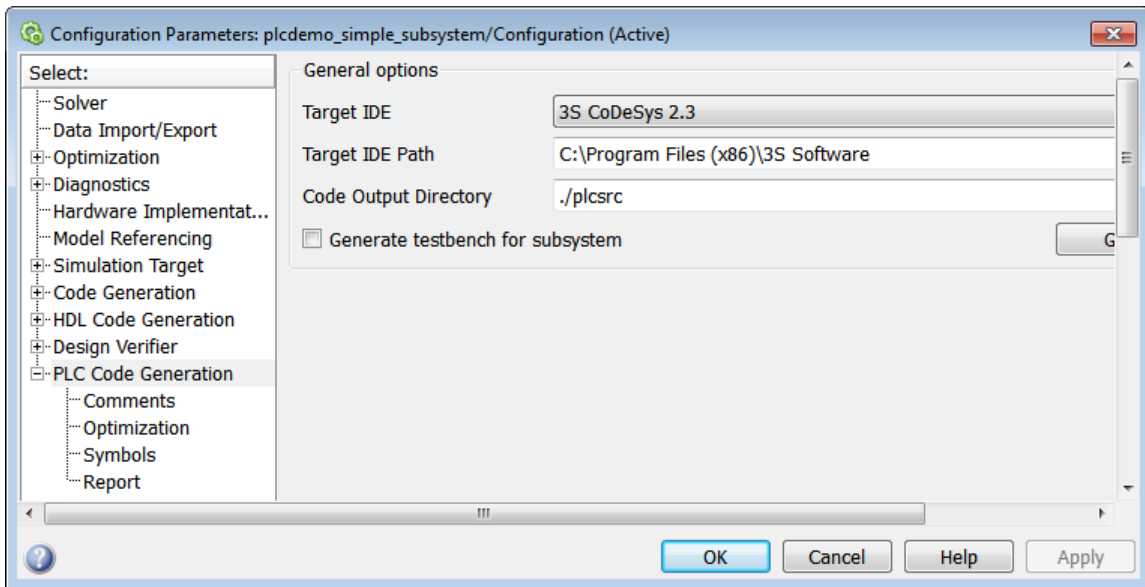

3 In **PLC Code > General options > Target IDE**, select a target IDE. For example, select CoDeSys 2.3.

4 Click **Apply**.

5 Click the **Generate code** button.

This button:

- Generates structured text code (same as the **PLC Code > Generate Code for Subsystem** option)
- Stores generated code in *model_name.exp* (for example, *plcdemo_simple_subsystem.exp*)

When code generation is complete, an information window is displayed.

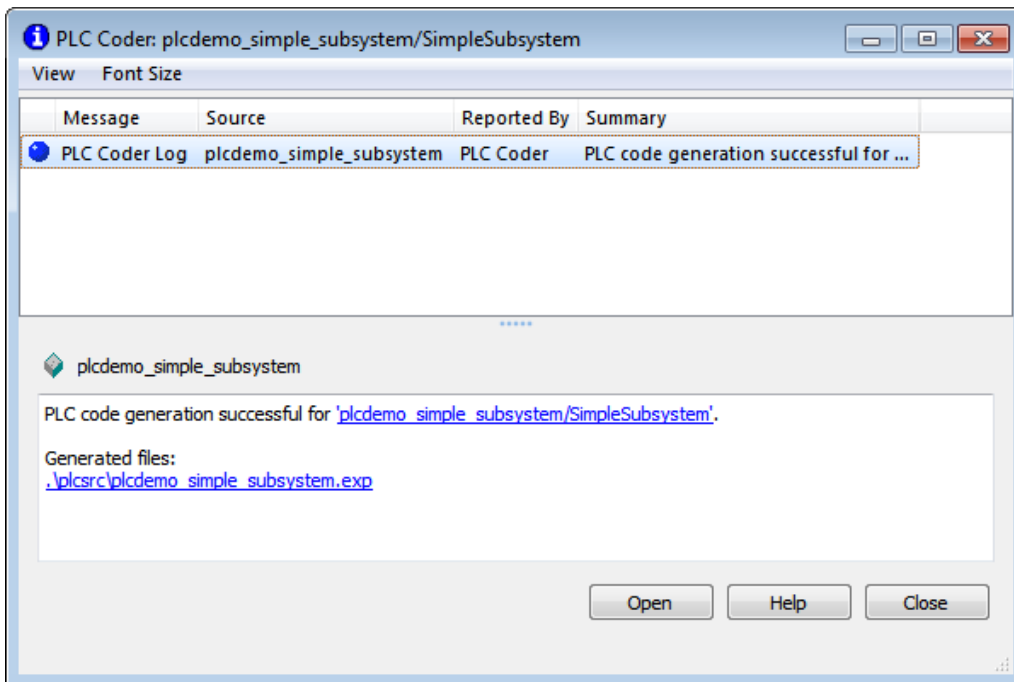

This window has links that you can click to open the associated files.

The Simulink PLC Coder software generates structured text code and stores it according to the target IDE platform. These platform-specific paths are default locations for the generated code. To customize generated file names, see “Specify Custom Names for Generated Files” on page 1-26.

Platform	Generated Files
3S-Smart Software Solutions CoDeSys 2.3	<i>current_folder\plcsrc\model_name.exp</i> — Structured text file for importing to the target IDE.
33S-Smart Software Solutions CoDeSys 3.3	<i>current_folder\plcsrc\model_name.xml</i> — Structured text file for importing to the target IDE.
B&R Automation Studio IDE	<p>The following files in <i>current_folder\plcsrc\model_name</i> — Files for importing to the target IDE:</p> <ul style="list-style-type: none"> • <i>Package.pkg</i> — (If test bench is generated) Top-level package file for function blocks library and test bench main program in XML format. <p>In the main folder (if test bench is generated):</p> <ul style="list-style-type: none"> • <i>IEC.prg</i> — Test bench main program definition file in XML format. • <i>mainInit.st</i> — Text file. Test bench init program file in structured text. • <i>mainCyclic.st</i> — Text file. Test bench cyclic program file in structured text. • <i>mainExit.st</i> — Text file. Test bench exit program file in structured text. • <i>main.typ</i> — Text file. Main program type definitions file in structured text. • <i>main.var</i> — Text file. Main program variable definitions file in structured text.
Beckhoff TwinCAT 2.11	<i>current_folder\plcsrc\model_name.exp</i> — Structured text file for importing to the target IDE.
KW-Software MULTIPROG 5.0	<i>current_folder\plcsrc\model_name.xml</i> — Structured text file, in XML format, for importing to the target IDE.
Phoenix Contact PC WORX 6.0	<i>current_folder\plcsrc\model_name.xml</i> — Structured text file, in XML format, for importing to the target IDE.

Platform	Generated Files
Rockwell Automation RSLogix 5000 IDE: AOI	<i>current_folder\plcsrc\model_name.L5X</i> — (If test bench is generated) Structured text file for importing to the target IDE using Add-On Instruction (AOI) constructs. This file is in XML format and contains the generated structured text code for your model.
Rockwell Automation RSLogix 5000 IDE: Routine	<p><i>current_folder\plcsrc\model_name.L5X</i> — (If test bench is generated) Structured text file for importing to the target IDE using routine constructs. This file is in XML format and contains the generated structured text code for your model.</p> <p>In <i>current_folder\plcsrc\model_name</i> (if test bench is not generated), the following files are generated:</p> <ul style="list-style-type: none"> • <i>subsystem_block_name.L5X</i> — Structured text file in XML format. Contains program tag and UDT type definitions and the routine code for the top-level subsystem block. • <i>routine_name.L5X</i> — Structured text files in XML format. Contains routine code for other subsystem blocks.
Siemens SIMATIC STEP 7 IDE	<p><i>current_folder\plcsrc\model_name\model_name.scl</i> — Structured text file for importing to the target IDE.</p> <p><i>current_folder\plcsrc\model_name\model_name.asc</i> — (If test bench is generated) Text file. Structured text file and symbol table for generated test bench code.</p>
Generic	<i>current_folder\plcsrc\model_name.st</i> — Pure structured text file. If your target IDE is not available for the Simulink PLC Coder product, consider generating and importing a generic structured text file.
PLCopen XML	<i>current_folder\plcsrc\model_name.xml</i> — Structured text file formatted using the PLCopen XML standard. If your target IDE is not available for the Simulink PLC Coder product, but uses a format like this standard, consider generating and importing a PLCopen XML structured text file.

The example in this topic illustrates generated code for the CoDeSys Version 2.3 PLC IDE. Generated code for other platforms, such as Rockwell Automation RSLogix 5000, is in XML or other format and looks different.

```

15 FUNCTION_BLOCK SimpleSubsystem
16 VAR_INPUT
17     ssMethodType: SINT;
18     U: LREAL;
19 END_VAR
20 VAR_OUTPUT
21     Y: LREAL;
22 END_VAR
23 VAR
24     UnitDelay_DSTATE: LREAL;
25 END_VAR
26 VAR_TEMP
27     rtb_Gain: LREAL;
28 END_VAR
29 CASE ssMethodType OF
30     SS_INITIALIZE:
31         (* InitializeConditions for UnitDelay: '<S1>/Unit Delay' *)
32         UnitDelay_DSTATE := 0;
33
34     SS_OUTPUT:
35         (* Gain: '<S1>/Gain' incorporates:
36          *   Inport: '<Root>/U'
37          *   Sum: '<S1>/Sum'
38          *   UnitDelay: '<S1>/Unit Delay'
39          *)
40         rtb_Gain := (U - UnitDelay_DSTATE) * 0.5;
41
42         (* Outport: '<Root>/Y' *)
43         Y := rtb_Gain;
44
45         (* Update for UnitDelay: '<S1>/Unit Delay' *)
46         UnitDelay_DSTATE := rtb_Gain;
47
48 END_CASE;
49 END FUNCTION_BLOCK

```

For a description of how the generated code for the Simulink components map to structured text components, see “Simulink® PLC Coder™ Mapping Semantics” on page 2-2.

If you are confident that the generated structured text is good, optionally change your workflow to automatically generate and import code to the target IDE. For more information, see “Import Structured Text Code Automatically” on page 1-31.

Generate Structured Text with the MATLAB Interface

You can generate structured text code for a subsystem from the MATLAB Command Window with the `plcgeneratecode` function. The function assumes that you have configured the parameters for the model, or that you

want to use the default settings. For example, to open the Configuration Parameters dialog box for the subsystem, type:

```
plcopenconfigset('plcdemo_simple_subsystem/Simple_Subsystem')
```

Configure the subsystem as described in “Generate Structured Text from the Model Window” on page 1-19.

To generate the code for the subsystem, type:

```
generatedfiles = plcgeneratecode('plcdemo_simple_subsystem/Simple_Subsystem')
```

Generate Structured Text Code and Integrate with Existing Siemens SIMATIC STEP 7 Projects

This topic describes a workflow to integrate generated code into an existing Siemens SIMATIC STEP 7 project.

This topic assumes that:

- You have generated code for the Siemens SIMATIC STEP 7 target IDE. If you have not yet done so, see “Generate Structured Text from the Model Window” on page 1-19.
- You have a Siemens SIMATIC STEP 7 project into which you want to integrate the generated code.

- 1** In the Siemens SIMATIC STEP 7 project, right-click **Sources** and select **Insert New Object > External Source**.

A browser window is displayed.

- 2** In the browser window, navigate to the folder that contains the Simulink PLC Coder generated code you want to integrate.

- 3** In this folder, select *model_name*.sc1, then click **OK**.

A new entry named *model_name* appears in the **Sources** folder.

- 4** In the **Sources** folder, double-click *model_name*.

The generated code is listed in the SCL editor window.

- 5 In the SCL editor window, select **Options > Customize**.

The customize window is displayed.

- 6 In the customize window, select **Create block numbers automatically**.

- 7 Click **OK**.

This action enables the software to generate automatically the symbol addresses for Subsystem blocks.

- 8 In the SCL editor window, compile the `model_name.scl` file for the Subsystem block.

The new Function Block is now integrated and available for use with the existing Siemens SIMATIC STEP 7 project.

Matrix Data Types

The coder converts matrix data types to single-dimensional vectors (column-major) in the generated structured text.

Generated Code Header

After generating structured text code, examine it. If your model has author names, creation dates, and model descriptions, the generated code contains these items in the header comments. The header also lists fundamental sample times for the model and the subsystem block for which you generate code.

Specify Custom Names for Generated Files

To specify a different name for the generated files, set the **Function name options** parameter in the Subsystem block:

- 1 Right-click the Subsystem block for which you want to generate code and select **Subsystem Parameters**.
- 2 In the Main tab, select the **Treat as atomic unit** check box.

- 3 Click the **Code Generation** tab.
- 4 From the **Function Packaging** parameter list, select either **Function** or **Reusable Function**.

These options enable the **Function name options** and **File name options** parameters.

- 5 Select the option that you want to use for generating the file name:

Function name options	Generated File Name
Auto	Default. Uses the model name, as listed in “Prepare Model for Structured Text Generation” on page 1-11, for example, <code>plcdemo_simple_subsystem</code> .
Use subsystem name	Uses the subsystem name, for example, <code>SimpleSubsystem</code> .
User specified	Uses the custom name that you specify in the Function name parameter, for example, <code>SimpleSubsystem</code> .

Propagation of Block Descriptions

To propagate blocks to generated code for all target IDEs:

- 1 Right-click the block for which you want to propagate comments.
- 2 From the menu, select **Properties**.
- 3 In the **General** tab, navigate to the **Description** section and enter the text that you want to propagate and save the changes.
- 4 In the **Configuration Parameters** dialog box, click the **PLC Code Generation > Comments > Include block description** check box and save the changes.
- 5 Generate code for the model as usual and observe that the comments have propagated to the generated code.

For Rockwell Automation RSLogix 5000 AOI/routine target IDEs, the coder also generates the subsystem block description text as an AOI or routine description L5X XML tag. The IDE can then import the tag as part of AOI and routine definition in the generated code.

Internal Signals for Debugging in RSLogix 5000 IDE

For debugging, you might want to generate code for test point outputs from the top level subsystem of your model. The coder generates code that maps the test pointed output to optional AOI output parameters for RSLogix 5000 IDEs. In the generated code, the variable tags that correspond to the test points have the property `Required=false`. This example assumes that you have a model appropriately configured for the coder, such as `plcdemo_simple_subsystem`.

- 1 If you do not have the `plcdemo_simple_subsystem` model open, open it now.
- 2 In the Configuration Parameters dialog box, set **Target IDE** to Rockwell RSLogix 5000: AOI.
- 3 In the top level subsystem of the model, right-click the output line and select **Properties**.

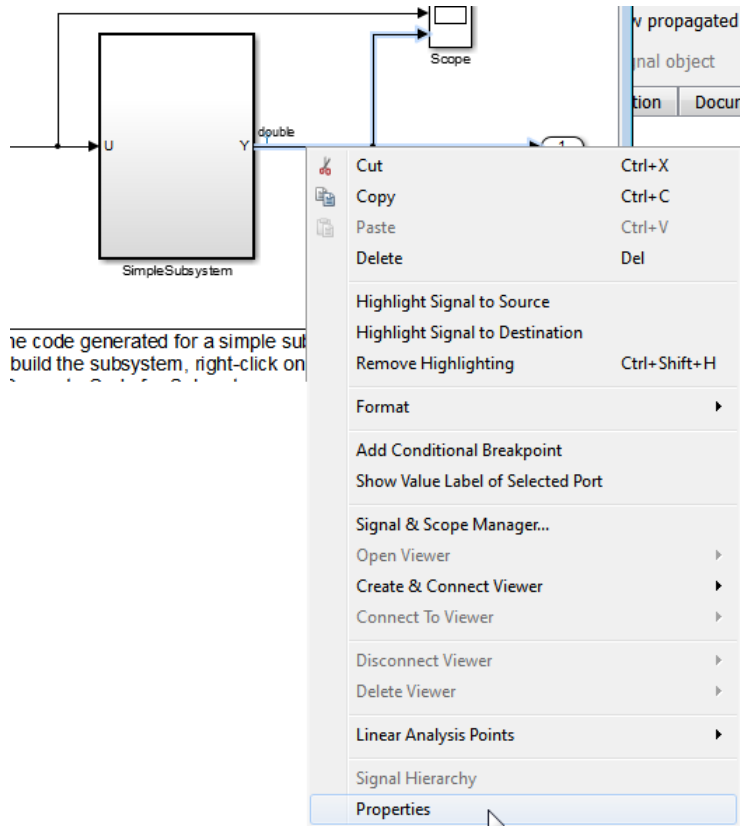

The Signal Properties dialog box is displayed.

- 4** On the **Logging and accessibility** tab, click the **Test point** check box.

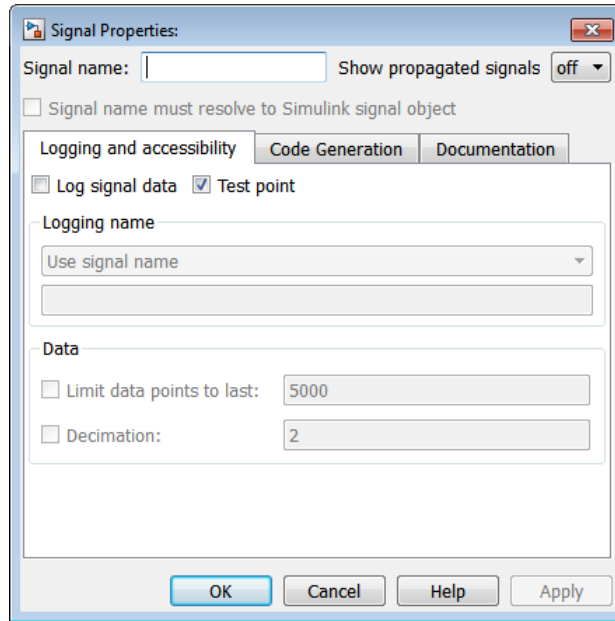

5 Click **OK**.

6 Generate code for the top level subsystem.

7 Inspect the generated code for the string `Required=false`.

For more information on signals with test points, see “What Is a Test Point?”.

Import Structured Text Code Automatically

In this section...

“PLC IDEs That Qualify for Importing Code Automatically” on page 1-31

“Generate and Automatically Import Structured Text Code” on page 1-32

“Troubleshoot Automatic Import Issues” on page 1-33

PLC IDEs That Qualify for Importing Code Automatically

If you are confident that your model produces structured text that does not require visual examination, you can generate and automatically import structured text code to one of the following target PLC IDEs:

- 3S-Smart Software Solutions CoDeSys Version 2.3
- KW-Software MULTIPROG Version 5.0
- Phoenix Contact PC WORX Version 6.0
- Rockwell Automation RSLogix 5000 Version 17, 18, or 19

For the Rockwell Automation RSLogix routine format, you must generate testbench code for automatic import and verification.

- Siemens SIMATIC STEP 7 Version 5.4 only for the following versions:
 - Siemens SIMATIC Manager: Version V5.4+SP5+HF1, Revision K5.4.5.1
 - S7-SCL: Version V5.3+SP5, Revision K5.3.5.0
 - S7-PLCSIM: Version V5.4+SP3, Revision K5.4.3.0

This topic describes how to work with the default CoDeSys Version 2.3 IDE. The procedure should work without additional changes for the other supported PLC IDEs, with the exception of the KW-Software MULTIPROG 5.0 and Phoenix Contact PC WORX 6.0 IDE. For notes on how to automatically import structured text code to these IDEs, see “Import and Verify Structured Text to KW-Software MULTIPROG 5.0 and Phoenix Contact PC WORX 6.0 IDEs Automatically” on page 3-9.

Generate and Automatically Import Structured Text Code

You can generate and automatically import structured text code. Before you start:

- In the target IDE, save any current project.
- Close all open projects.
- Close the target IDE and all target IDE-related windows.

Note While the automatic import process is in progress, do not touch your mouse or keyboard. Doing so might disrupt the automatic import process. You can resume normal operations when the process completes.

The following procedure assumes that you have installed your target PLC IDE in a default location and uses the CoDeSys V2.3 IDE. If you installed the target PLC IDE in a nondefault location, open the Configuration Parameters dialog box. In the PLC Coder node, set the **Target IDE Path** parameter to the installation folder of your PLC IDE. See “Target IDE Path” on page 12-6 for more details.

- 1 If it is not already started, start the MATLAB Command Window.
- 2 Open the `plcdemo_simple_subsystem` model.
- 3 Right-click the Subsystem block and select **PLC Code > Generate and Import Code for Subsystem**.

The software then:

- a Generates the code.
- b Starts the target IDE interface.
- c Creates a new project.
- d Imports the generated code to the target IDE.

If you want to generate, import, and run the structured text code, see “Import and Verify Structured Text Code Automatically” on page 3-9.

Troubleshoot Automatic Import Issues

This topic describes guidelines, hints, and tips for questions or issues you might have while using the automatic import capability of the Simulink PLC Coder product.

Supported Target IDEs

The Simulink PLC Coder software supports only the following versions of target IDEs for automatic import and verification:

- 3S-Smart Software Solutions CoDeSys Version 2.3
- KW-Software MULTIPROG 5.0 (English)
- Phoenix Contact PC WORX 6.0 (English)
- Rockwell Automation RSLogix 5000 Series Version 17, 18, 19 (English)

For the Rockwell Automation RSLogix routine format, you must generate testbench code for automatic import and verification.

- Siemens SIMATIC STEP 7 Version 5.4 (English and German)

Unsupported Target IDEs

The following target IDEs currently do not support automatic import. For these target IDEs, the automatic import menu items (**Generate and Import Code for Subsystem** and **Generate, Import, and Verify Code for Subsystem**) are disabled.

- 3S-Smart Software Solutions CoDeSys Version 3.3
- B&R Automation Studio IDE
- Beckhoff TwinCAT 2.11
- Generic
- PLCopen

Possible Automatic Import Issues

When the Simulink PLC Coder software fails to finish automatically importing for the target IDE, it reports an issue in a message dialog box. To remedy issue, try the following actions:

- Check that the coder supports the target IDE version and language setting combination.
- Check that you have specified the target IDE path in the subsystem Configuration Parameters dialog box.
- Close any currently open projects in the target IDE, close the target IDE completely, and try again.
- Some target IDEs can have issues supporting the large data sets the coder test bench generates. In these cases, try to shorten the simulation cycles to reduce the data set size, then try the automatic import again.
- Other applications can interfere with automatic importing to a target IDE. Try to close other unrelated applications on the system and try the automatic import again.

Integrate Absolute Time Temporal Logic Code

Use this workflow to generate code with absolute time temporal logic for targets other than Rockwell Automation RSLogix 5000 IDE. The coder supports absolute time temporal logic automatically for the Rockwell Automation RSLogix 5000 IDE.

This workflow refers to `plcdemo_sf_abs_time` as an example of a model that contains absolute time temporal logic constructs.

Before you start:

- In your IDE, create a `PLC_CODER_TIMER` function block for your absolute time temporal logic constructs. In this block, define the code for the timer logic. When the Simulink PLC Coder product generates code for a model that uses absolute time temporal logic, it generates calls to this block in the code to implement timer logic. See `\toolbox\plccoder\plccoderdemos\plc_coder_timer.st` for an example `PLC_CODER_TIMER` definition for the generic IDE.

```

|(*
|*
|* File: plc_coder_timer.st
|*
|* Template file (in generic ST format) showing the code for
|* PLC_CODER_TIMER function block used for absolute time temporal logic.
|* This file assumes that there is a function 'TickCounter' which returns
|* the current time as a DINT number. You will need to modify this
|* template file to correctly compile on your target PLC IDE and
|* integrate it with the generated code to support absolute time temporal
|* logic.
|*
|* Copyright 2012 MathWorks, Inc.
|*)
FUNCTION_BLOCK PLC_CODER_TIMER
VAR_INPUT
    timerAction: DINT;    (* select timer action method; see below *)
    maxTime: DINT;       (* maximum timer count (in milliseconds) *)
END_VAR
VAR_OUTPUT
    done: BOOL;          (* status var to check if the timer operation is done *)
END_VAR
VAR
    tickStore: DINT;
END_VAR
CASE timerAction OF
    1:
        (* RESET: code for resetting the timer count goes here *)
        tickStore := TickCounter();
        done := FALSE;
    2:
        (* AFTER: code for checking whether the timer is past maxTime count goes here *)
        done := (TickCounter() - tickStore) >= maxTime;
    3:
        (* BEFORE: code for checking whether the timer is NOT yet past maxTime count goes here *)
        done := (TickCounter() - tickStore) < maxTime;
END_CASE;
END_FUNCTION_BLOCK

```

The input/output interface and logic of the PLC_CODER_TIMER function block in your IDE must match the definition in this example.

- Check that you have a Stateflow license. The coder supports absolute time temporal logic constructs that you specify in Stateflow charts.
- 1** Create your model using absolute time temporal logic constructs. Include the temporal logic constructs in a Stateflow chart. For an example, see `plcdemo_sf_abs_time`.

- 2 Configure the chart to generate Simulink PLC Coder code.
- 3 Generate code for the chart.
- 4 In the generated code, look for instances of PLC_CODER_TIMER. For example:

```

CASE is_c2_Temporal OF
  1:
    (* During 'A': '<S1>:1' *)
    PLC_CODER_TIMER(temporalCounter_i1, 2, 3000, temp1);
    IF temp1 THEN
      (* Transition: '<S1>:4' *)
      is_c2_Temporal := 2;
      PLC_CODER_TIMER(temporalCounter_i1, 1, 0, temp1);
    ELSE
      (* Outport: '<Root>/pulse' *)
      pulse := 1.0;
    END_IF;
  2:
    (* During 'B': '<S1>:2' *)
    PLC_CODER_TIMER(temporalCounter_i1, 2, 4000, temp1);
    IF temp1 THEN
      (* Transition: '<S1>:8' *)
      is_c2_Temporal := 3;
      PLC_CODER_TIMER(temporalCounter_i1, 1, 0, temp1);
    ELSE

```

- 5 Integrate the generated code and the PLC_CODER_TIMER function block into your IDE.

Simulation and Code Generation of Motion Instructions

In this section...
“Workflow for Using Motion Instructions in Model” on page 1-38
“Library of Motion Instructions” on page 1-41
“Data Types for Motion Instructions” on page 1-41
“Limitations for MAM Instruction” on page 1-42

The Simulink PLC Coder software supports a workflow for the behavioral simulation and code generation of motion instructions for the Rockwell Automation RSLogix 5000 IDE.

Workflow for Using Motion Instructions in Model

This workflow uses `plcdemo_motion_control` in the `plcdemos` folder. This example provides a template that you can use with motion instructions. It contains the following subsystems:

Subsystem	Description
Controller	<p>Contains an example Stateflow chart with motion instructions. The controller subsystem sends inputs to the Command Profile subsystem (part of the template).</p> <p>Replace this subsystem with your own controller subsystem.</p>
Command Profile	<p>Contains a utility subsystem in which the coder calculates the position data based on the parameters of the motion instructions MAM command. Typically, you do not need to modify this subsystem.</p> <p>Do not need to replace this subsystem.</p>

Subsystem	Description
Drive Model	<p>Contains a minimalistic drive model.</p> <p>Replace this subsystem with your own drive model subsystem.</p>
Drive Status	<p>Contains a utility subsystem that reads drive status and returns that status to the Controller subsystem. Typically, you do not need to modify this subsystem.</p> <p>Do not need to replace this subsystem.</p>

Before you start, create

- A custom controller subsystem. This subsystem contains motion instructions. The controller subsystem sends inputs to the Command Profile subsystem.
- A custom drive (plant) model subsystem. The subsystem sends inputs to a Drive Status subsystem. Design the subsystem to work with the inputs and outputs.

To modify the `plcdemo_motion_control` example:

- 1 Open the `plcdemo_motion_control` example template.
- 2 Replace the `ExampleController` chart in the Controller subsystem with your controller subsystem.
- 3 Replace the Drive Model subsystem in the template with your drive (plant) model.
- 4 Simulate the model.
- 5 Observe the simulation results in the model scopes.

The following shows the output from `plcdemo_motion_control` without modification.

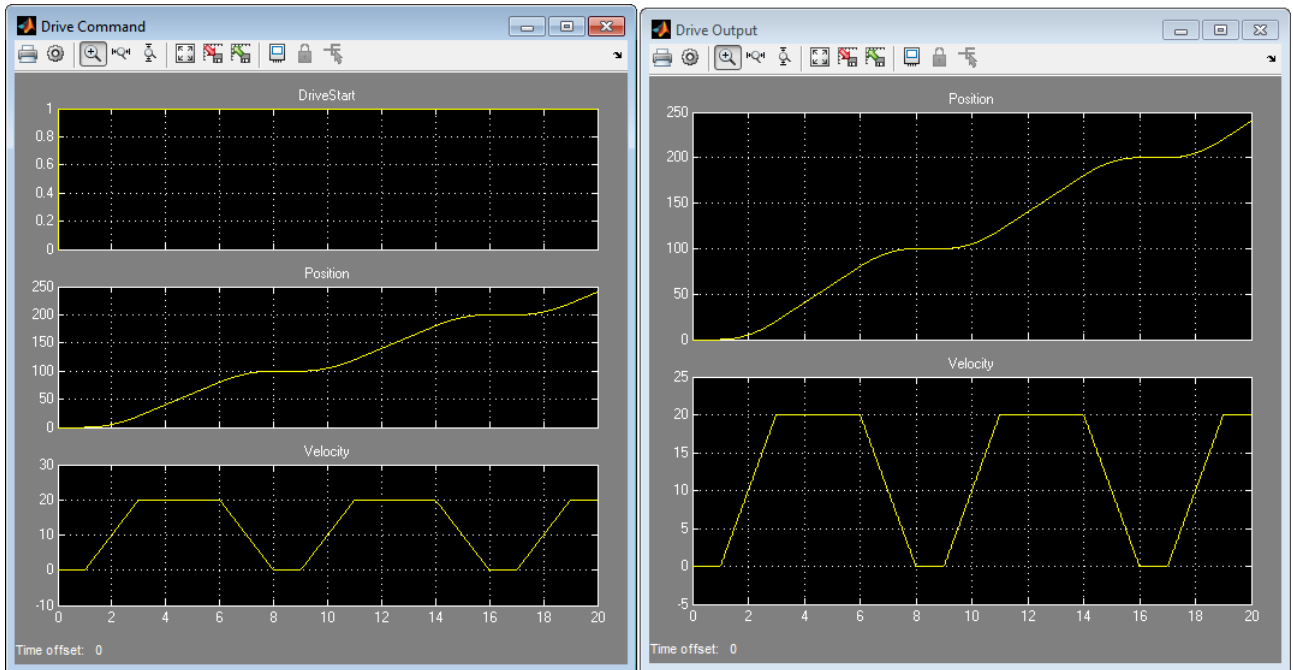

- 6 Generate code for the example model. To view the code in HTML format, in the coder configuration parameters, select the **PLC Code Generation > Report > Generate traceability report** check box and click **Apply**.

Navigate to the **PLC Code Generation** node and click **Generate code**.

An HTML file of the generated code is displayed.

- 7 Observe the generated code for MAM, MAFR, and MSO.

```

ELSE
  (* During 'Init': '<S2>:1' *)
  IF NOT Axis.ServoActionStatus THEN
    (* Transition: '<S2>:1' *)
    MAFR(Axis, MC_MAFR_STAxis);
    MSO(Axis, MSO_STAxis);
    is_c1_Controller := 2;
    PLC_CODER_TIMER(temporalCounter_11, 1, 0, temp1);
    (* Entry 'Init': '<S2>:1' *)
    (* A very simple controller that will check if the axis is ready to move
    and if so will execute a move cmd.
    If the axis is off or in error it will try to reset and restart.
    MAM_1 is the instance tag of the move cmd
    Axis_1 is the axis tag (need to be passes by reference) *)
    dMoveType := 1;
    rPosition := 100.0;
    rSpeed := 20.0;
    rAccRate := 10.0;
    rDecRate := rAccRate;
    rAccJerk := 20.0;
    rDecJerk := rAccJerk;
  ELSE
    PLC_CODER_TIMER(temporalCounter_11, 2, 1000, temp1);
    IF (Axis.ServoActionStatus AND ( NOT MC_MAM_Axis.IP)) AND temp1 THEN
      (* Transition: '<S2>:3' *)
      is_c1_Controller := 1;
      (* Entry 'DoMove': '<S2>:2' *)
      (* Motion Axis Move Command *)
      MAM(Axis, MC_MAM_Axis, dMoveType, rPosition, rSpeed, 0, rAccRate, 0, rDecRate, 0, 1, rAccJerk, rDecJerk, 1, 0, 0);
    
```

MAFR and MSO

MAM

Library of Motion Instructions

The `plcdemo_motion_control` example uses a motion instructions library that contains a Motion Stub Functions Stateflow chart. This chart defines stub functions for only the following motion instructions:

- MAM
- MAFR
- MSO

To use other Rockwell Automation RSLogix motion instructions in the model, you must define your own stub functions to correspond to the RSLogix motion instructions in the Motion Stub Functions chart.

Data Types for Motion Instructions

The `plcdemo_motion_control` example uses Simulink bus data types (`Simulink.Bus`) that correspond to the motion instruction `AXIS` and `MOTION_INSTRUCTION` user-defined data types (UDTs) in the Rockwell

Automation RSLogix 5000 IDE. For these UDTs, the example defines only the fields used in the ExampleController chart of the `plcdemo_motion_control` example. When you generate code, the coder maps the bus data types to the motion instruction UDTs. If your controller subsystem uses any other fields of motion instruction UDTs, you must add them to the definition of the corresponding Simulink bus data types. The `/toolbox/plccoder/plccoderdemos/PLCMotionType.mat` file contains the definitions of the Simulink bus data types. As needed by your controller, you can add more fields to these definitions.

Name	Size	Bytes	Class	Attributes
AXIS_SERVO_DRIVE	1x1		Simulink.Bus	
MOTION_INSTRUCTION	1x1		Simulink.Bus	

Limitations for MAM Instruction

In the `plcdemo_motion_control` example, the MAM instruction has the following limitations:

- 1** Direction parameter is always forward.
- 2** The software supports only the Trapezoidal profile.
- 3** The software ignores all units parameters.
- 4** The software does not support Merge and Merge speed.

Mapping Simulink Semantics to Structured Text

- “Simulink® PLC Coder™ Mapping Semantics” on page 2-2
- “Generated Code Structure for Simple Simulink Subsystems” on page 2-3
- “Generated Code Structure for Reusable Subsystems” on page 2-5
- “Generated Code Structure for Triggered Subsystems” on page 2-7
- “Generated Code Structure for Stateflow Charts” on page 2-9
- “Generated Code Structure for MATLAB Function Block” on page 2-11

Simulink PLC Coder Mapping Semantics

When you examine generated code, you evaluate how well the Simulink PLC Coder software has generated code from your model. The following topics describe how the coder maps Simulink subsystem semantics to function block semantics in structured text. As examples, the topics describe the mapping in the context of the different subsystem types that Simulink supports. The examples assume that you have already generated code (see “Generate Structured Text from the Model Window” on page 1-19). These topics use code generated with CoDeSys Version 2.3. All examples are located in the *matlabroot\toolbox\plccoder\plccoderdemos* folder.

Generated Code Structure for Simple Simulink Subsystems

This topic assumes that you have generated structured text code from a Simulink model. If you have not yet done so, see “Generate Structured Text from the Model Window” on page 1-19.

The example in this topic shows generated code for the CoDeSys Version 2.3 IDE. Generated code for other IDE platforms looks different.

- 1 If you do not have the `plcdemo_simple_subsystem.exp` file open, open it in the MATLAB editor. In the folder that contains the file, type:

```
edit plcdemo_simple_subsystem.exp
```

A file like the following is displayed.

The following figure illustrates the mapping of the generated code to structured text components for a simple Simulink subsystem. The Simulink subsystem corresponds to the structured text function block, `Subsystem`.

Note The coder maps alias data types to the base data type in the generated code.

Input parameter for subsystem method type

Atomic subsystem name

Subsystem

Subsystem inputs and outputs

Subsystem State (DWork) variables

Initialize and step methods

```

16 FUNCTION_BLOCK SimpleSubsystem
17 VAR_INPUT
18   ssMethodType: SINT;
19   U: LREAL;
20 END_VAR
21 VAR_OUTPUT
22   Y: LREAL;
23 END_VAR
24 VAR
25   UnitDelay_DSTATE: LREAL;
26 END_VAR
27 VAR_TEMP
28   rtb_Gain: LREAL;
29 END_VAR
30 CASE ssMethodType OF
31   SS_INITIALIZE:
32
33     (* InitializeConditions for UnitDelay: '<S1>/Unit Delay' *)
34     UnitDelay_DSTATE := 0;
35   SS_STEP:
36
37     (* Gain: '<S1>/Gain' incorporates:
38      * Import: '<Root>/U'
39      * Sum: '<S1>/Sum'
40      * UnitDelay: '<S1>/Unit Delay' *)
41     rtb_Gain := (U - UnitDelay_DSTATE) * 0.5;
42
43     (* Output: '<Root>/Y' *)
44     Y := rtb_Gain;
45
46     (* Update for UnitDelay: '<S1>/Unit Delay' *)
47     UnitDelay_DSTATE := rtb_Gain;

```

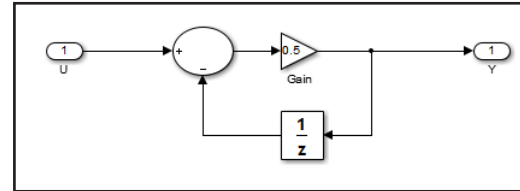

Inlined parameters

- 2 Inspect this code as you ordinarily do for PLC code. Check the generated code.

Generated Code Structure for Reusable Subsystems

This topic assumes that you have generated structured text code from a Simulink model. If you have not yet done so, see “Generate Structured Text from the Model Window” on page 1-19.

The example in this topic shows generated code for the CoDeSys Version 2.3 IDE. Generated code for other IDE platforms looks different.

- 1 Open the `plcdemo_reusable_subsystem` model.
- 2 Right-click the Subsystem block and select **PLC Code > Generate Code for Subsystem**.

The Simulink PLC Coder software generates structured text code and places it in `current_folder/plcsrc/plcdemo_reusable_subsystem.exp`.

- 3 If you do not have the `plcdemo_reusable_subsystem.exp` file open, open it in the MATLAB editor.

The following figure illustrates the mapping of the generated code to structured text components for a reusable Simulink subsystem . This graphic contains a copy of the hierarchical subsystem, `ReusableSubsystem`. This subsystem contains two identical subsystems, `S1` and `S2`. This configuration enables code reuse between the two instances (look for the `ReusableSubsystem` string in the code).

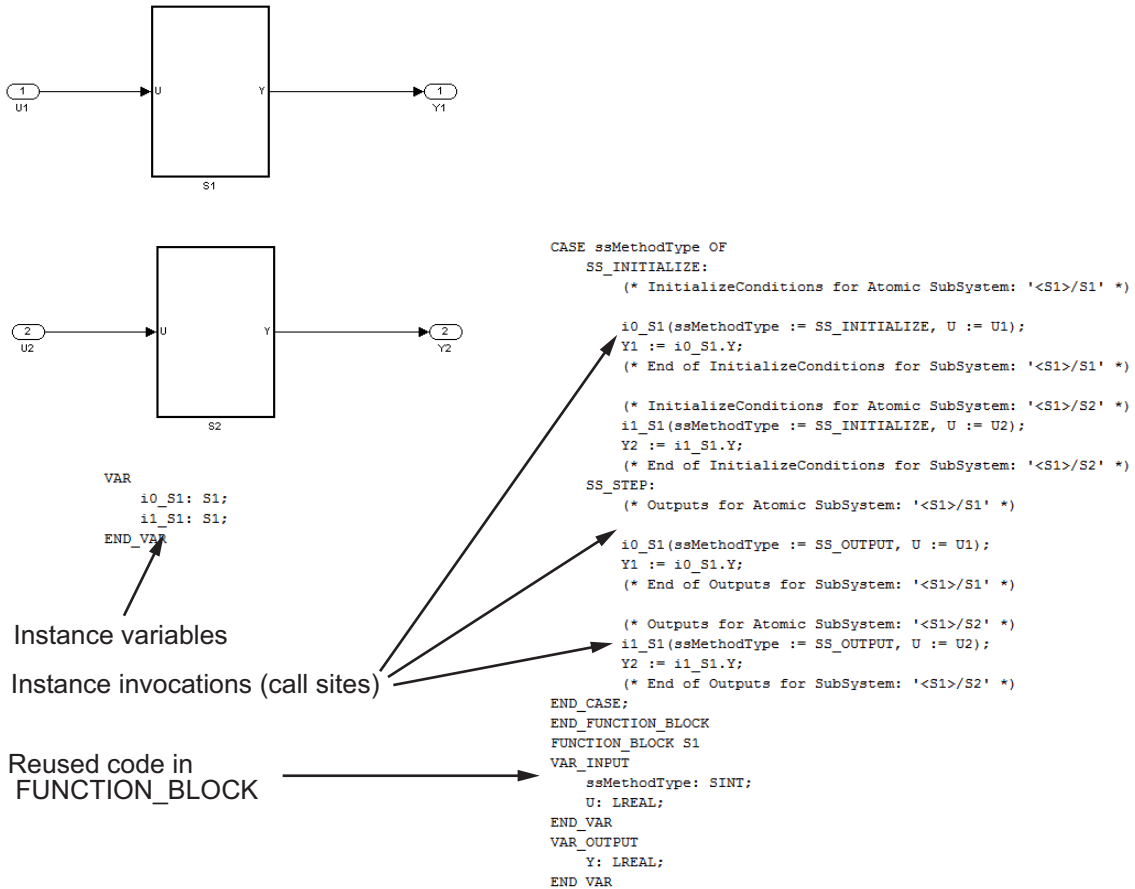

- 4** Examine the generated structured text code. The code defines FUNCTION_BLOCK ReusableSubsystem_S1 once.

Look for two instance variables that correspond to the two instances declared inside the parent FUNCTION_BLOCK ReusableSubsystem (_instance_ReusableSubsystem_S1_1: ReusableSubsystem_S1 and _instance_ReusableSubsystem_S1_0: ReusableSubsystem_S1). The code invokes these two instances separately by passing in different inputs. The code invokes the outputs per the Simulink execution semantics.

Generated Code Structure for Triggered Subsystems

This topic assumes that you have generated structured text code from a Simulink model. If you have not yet done so, see “Generate Structured Text from the Model Window” on page 1-19.

The example in this topic shows generated code for the CoDeSys Version 2.3 PLC IDE. Generated code for other IDE platforms looks different.

- 1 Open the `plcdemo_cruise_control` model.
- 2 Right-click the Controller subsystem block and select **PLC Code > Generate Code for Subsystem**.

The Simulink PLC Coder software generates structured text code and places it in `current_folder/plcsrc/plcdemo_cruise_control.exp`.

- 3 If you do not have the `plcdemo_cruise_control.exp` file open, open it in the MATLAB editor.

The following figure illustrates the mapping of the generated code to structured text components for a triggered Simulink subsystem. The first part of the figure shows the Controller subsystem and the triggered Stateflow chart that it contains. The second part of the figure shows excerpts of the generated code. Notice the zero-crossing functions that implement the triggered subsystem semantics.

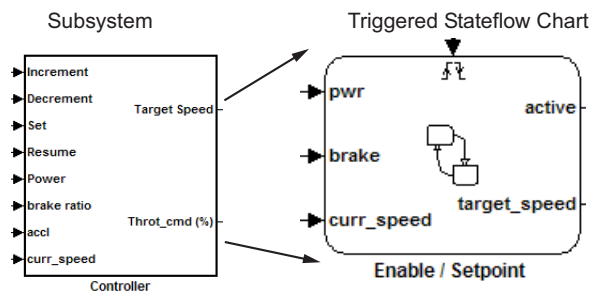

Generated code

```
EnableSetpoint_Trig_ZCE: ARRAY [0..6] OF USINT := 3,3,3,3,3,3,3;
i0_ZCFCN_d_ANY: ZCFCN_d_ANY;
END_VAR
...
...
...
SS_STEP:

(* DiscretePulseGenerator: '<S1>/Pulse Generator' *)
IF (clockTickCounter < 1) AND (clockTickCounter >= 0) THEN
  temp1 := 1.0;
ELSE
  temp1 := 0.0;
END_IF;
rtb_PulseGenerator := temp1;
IF clockTickCounter >= 1 THEN
  clockTickCounter := 0;
ELSE
  clockTickCounter := clockTickCounter + 1;
END_IF;
(* End of DiscretePulseGenerator: '<S1>/Pulse Generator' *)

(* Chart: '<S1>/Enable // Setpoint ' incorporates:
 * TriggerPort: '<S2>/ input events ' *)
tempInputSignal[0] := rtb_PulseGenerator;
(* Inport: '<Root>/Increment' *)
tempInputSignal[1] := Increment;
tempInputSignal[2] := Increment;
(* Inport: '<Root>/Decrement' *)
tempInputSignal[3] := Decrement;
tempInputSignal[4] := Decrement;
(* Inport: '<Root>/Set' *)
tempInputSignal[5] := Set;
(* Inport: '<Root>/Resume' *)
tempInputSignal[6] := Resume;
(* Chart: '<S1>/Enable // Setpoint ' incorporates:
 * TriggerPort: '<S2>/ input events ' *)
FOR inputEventIndex := 0 TO 6 DO
  i0_ZCFCN_d_ANY(u0 := EnableSetpoint_Trig_ZCE[inputEventIndex],
  callChartStep := i0_ZCFCN_d_ANY.y0,
  tmp := i0_ZCFCN_d_ANY.y1;
  tempOutEvent[inputEventIndex] := callChartStep;
  outState[inputEventIndex] := tmp;
...
...
...
FUNCTION_BLOCK ZCFCN_d_ANY
...
...
...
END_FUNCTION_BLOCK
```

Triggered subsystem semantics

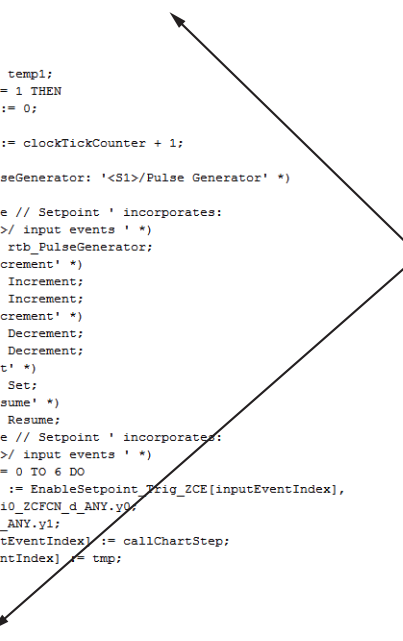

Generated Code Structure for Stateflow Charts

This topic assumes that you have generated structured text code from a Simulink model. If you have not yet done so, see “Generate Structured Text from the Model Window” on page 1-19.

The example in this topic shows generated code for the CoDeSys Version 2.3 PLC IDE. Generated code for other IDE platforms looks different.

- 1 Open the `plcdemo_stateflow_controller` model.
- 2 Right-click the ControlModule chart and select **PLC Code > Generate Code for Subsystem**.

The Simulink PLC Coder software generates structured text code and places it in `current_folder/plcsrc/plcdemo_stateflow_controller.exp`.

- 3 If you do not have the `plcdemo_stateflow_controller.exp` file open, open it in the MATLAB editor.

The following figure illustrates the mapping of the generated code to structured text components for a Simulink Subsystem block that contains a Stateflow chart.

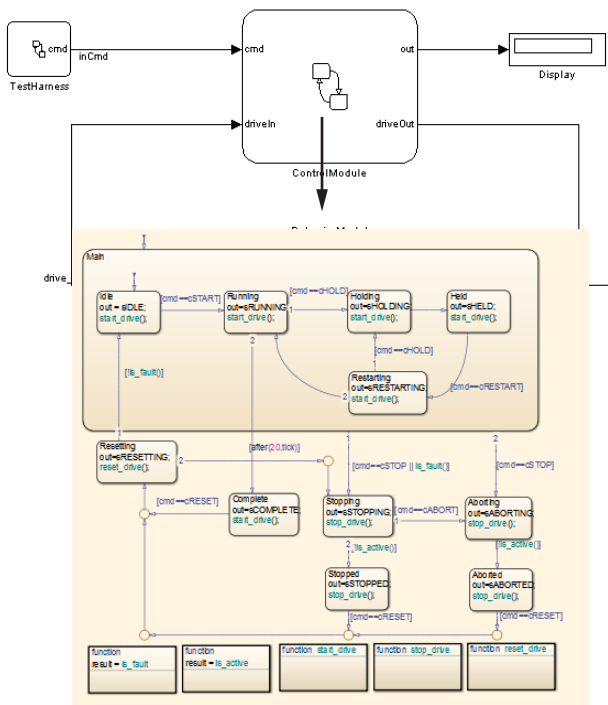

Inlined code for Stateflow chart

```

CASE is_c2_ControlModule OF
  ControlModule_IN_Aborted:
    (* During 'Aborted': '<S1>:12' *)
    IF inCmd = cRESET THEN
      (* Transition: '<S1>:40' *)
      (* Transition: '<S1>:41' *)
      (* Transition: '<S1>:38' *)
      (* Transition: '<S1>:35' *)
      (* Transition: '<S1>:33' *)
      is_c2_ControlModule := ControlModule_IN_Resetting;
      temporalCounter_11 := 0;
      (* Output: '<Root>/out' *)
      (* Entry 'Resetting': '<S1>:7' *)
      out := sRESETTING;
      (* Graphical Function 'reset_drive': '<S1>:92' *)
      (* Transition: '<S1>:94' *)
      driveOut.Start := FALSE;
      driveOut.Stop := FALSE;
      driveOut.Reset := TRUE;
    END_IF;
  ControlModule_IN_Aborting:
    ...
    ...
  END_IF;
  ControlModule_IN_Complete:
    (* During 'Complete': '<S1>:9' *)
    IF inCmd = cRESET THEN
      (* Transition: '<S1>:23' *)
      (* Transition: '<S1>:33' *)
      is_c2_ControlModule := ControlModule_IN_Resetting;
      temporalCounter_11 := 0;
      (* Output: '<Root>/out' *)
      (* Entry 'Resetting': '<S1>:7' *)
      out := sRESETTING;
      (* Graphical Function 'reset_drive': '<S1>:92' *)
      (* Transition: '<S1>:94' *)
      driveOut.Start := FALSE;
      driveOut.Stop := FALSE;
      driveOut.Reset := TRUE;
    END_IF;
  ControlModule_IN_Main:

```

4 Examine the generated structured text code.

The Simulink PLC Coder software aggressively inlines the generated code for the Stateflow chart. The coder performs this inlining because different functions from Stateflow charts share some global state data. However, function blocks in structured text code do not share state data. As a result, the coder software cannot map these functions onto separate function blocks. Instead, it must inline these functions.

Generated Code Structure for MATLAB Function Block

This topic assumes that you have generated structured text code from a Simulink model. If you have not yet done so, see “Generate Structured Text from the Model Window” on page 1-19.

The example in this topic shows generated code for the CoDeSys Version 2.3 IDE. Generated code for other IDE platforms looks different.

- 1 Open the `plcdemo_em1_tankcontrol` model.
- 2 Right-click the TankControl block and select **PLC Code > Generate Code for Subsystem**.

The Simulink PLC Coder software generates structured text code and places it in `current_folder/plcsrc/plcdemo_em1_tankcontrol.exp`.

- 3 If you do not have the `plcdemo_em1_tankcontrol.exp` file open, open it in the MATLAB editor.

The following figure illustrates the mapping of the generated code to structured text components for a Simulink Subsystem block that contains a MATLAB Function block. The coder tries to perform inline optimization on the generated code for MATLAB local functions. If the coder determines that it is more efficient to leave the local function as is, it places the generated code in a structured text construct called `FUNCTION`.

- 4 Examine the generated structured text code.

```
function [InFlow, OutFlow, StirSpeed] = TankControl(C:
    %%eml
    % Check the vessel state
    if(Height >= FullHeight)
        % Is it full ?
        vessel = PLCVesselState.FULL;
    elseif(Height <= EmptyHeight)
        % Is it empty ?
        vessel = PLCVesselState.EMPTIED;
    else
        vessel = PLCVesselState.NOT_FULL;
    end
```

MATLAB code

Generated code
for MATLAB
subfunctions

```
FUNCTION_BLOCK TankControl
VAR_INPUT
    Command: PLCCommandState;
    Height: LREAL;
END_VAR
VAR_OUTPUT
    InFlow: LREAL;
    OutFlow: LREAL;
    StirSpeed: LREAL;
END_VAR
VAR
    vessel: PLCVesselState;
    EmptyValve: PLCValveState;
    FillValve: PLCValveState;
END_VAR
(* Check the vessel state *)
IF Height >= 10.0 THEN
    (* Is it full ? *)
    vessel := FULL;
ELSIF Height <= 2.0 THEN
    (* Is it empty ? *)
    vessel := EMPTIED;
ELSE
    vessel := NOT_FULL;
END_IF;
(* Process the command mode *)
CASE Command OF
    FILL:
        (* Fill Tank *)
        EmptyValve := SHUT;
        IF vessel = FULL THEN
            FillValve := SHUT;
        ELSE
            FillValve := OPEN;
        END_IF;
    HOLD:
        (* Hold Contents *)
        EmptyValve := SHUT;
        FillValve := SHUT;
    EMPTY:
        (* Empty Tank *)
        FillValve := SHUT;
        IF vessel = EMPTIED THEN
            EmptyValve := SHUT;
        ELSE
            EmptyValve := OPEN;
        END_IF;
    ELSE
        EmptyValve := SHUT;
        FillValve := SHUT;
    END_CASE;
(* compute inflow and outflow *)
```

Generating Test Bench Code

- “Generated Structured Text and Test Bench Code” on page 3-2
- “Generate and Manually Import Test Bench Code” on page 3-5
- “Import and Verify Structured Text Code Automatically” on page 3-9

Generated Structured Text and Test Bench Code

In this section...
“Test Bench Verification” on page 3-2
“Generated Files” on page 3-2
“Integrate Generated Code into Custom Code” on page 3-2

Test Bench Verification

The Simulink PLC Coder software simulates your model and automatically captures the input and output signals for the subsystem that contains your algorithm. This set of input and output signal data is the test bench data. The coder also automatically generates a test bench (test harness) using the test bench data. The test bench runs the generated code to verify that the output is functionally and numerically equivalent to the output from the execution of a Simulink model. To perform this verification, import the generated structured text and the test bench data into your target IDE.

You can import test bench code:

- Manually, as described in “Generate and Manually Import Test Bench Code” on page 3-5.
- Automatically, including running the test bench, as described in “Import and Verify Structured Text Code Automatically” on page 3-9

Generated Files

Depending on the target IDE platform, the Simulink PLC Coder software generates code into one or more files. See “Generate Structured Text from the Model Window” on page 1-19 for list of the target IDE platforms and the possible generated files.

Integrate Generated Code into Custom Code

For the top-level subsystem that has internal state, the generated FUNCTION_BLOCK code has `ssMethodType`. `ssMethodType` is a special input argument that the coder adds to the input variables section of the FUNCTION_BLOCK section during code generation. `ssMethodType` enables you

to execute code for Simulink Subsystem block methods such as initialization and computation steps. The generated code executes the associated CASE statement based on the value passed in for this argument.

To use `ssMethodType` with a `FUNCTION_BLOCK` for your model, in the generated code, the top-level subsystem function block prototype has one of the following formats:

Has Internal State	ssMethodType Contains...
Yes	The generated function block for the block will have an extra first parameter <code>ssMethodType</code> of integer type. This extra parameter is in addition to the function block I/O parameters mapped from Simulink block I/O ports. To use the function block, first initialize the block by calling the function block with <code>ssMethodType</code> set to integer constant <code>SS_INITIALIZE</code> . If the IDE does not support symbolic constants, set <code>ssMethodType</code> to integer value 0. For each follow-up invocation, call the function block with <code>ssMethodType</code> set to constant <code>SS_STEP</code> . If the IDE does not support symbolic constants, set <code>ssMethodType</code> to integer value 1. These settings cause the function block to initialize or compute and return output for each time step.
No	The function block interface only has parameters mapped from Simulink block I/O ports. There is no <code>ssMethodType</code> parameter. To use the function block in this case, call the function block with I/O arguments.

For non top-level subsystems, in the generated code, the subsystem function block prototype has one of the following formats:

Has Internal State	ssMethodType Contains...
Yes	The function block interface has the <code>ssMethodType</code> parameter. The generated code might have <code>SS_INITIALIZE</code> , <code>SS_OUTPUT</code> , or other <code>ssMethodType</code> constants to implement Simulink semantics.
No	The function block interface only has parameters mapped from Simulink block I/O ports. There is no <code>ssMethodType</code> parameter.

Generate and Manually Import Test Bench Code

This example shows how to generate test bench code. It uses the CoDeSys V2.3 IDE as an example target IDE.

This example assumes that you have an appropriately configured model from which to generate structured text. If you have not yet done this procedure, see “Prepare Model for Structured Text Generation” on page 1-11. All demos are located in the *matlabroot*\toolbox\plccoder\plccoderdemos folder.

- 1** If you do not have the `plcdemo_simple_subsystem` model open, open it now.
- 2** Check that you have connected the inputs and outputs of the subsystem for which you want to generate the test bench. You can import this test bench with the generated code to the target IDE to verify that the output is functionally and numerically equivalent to the output from the execution of a Simulink model. For example:

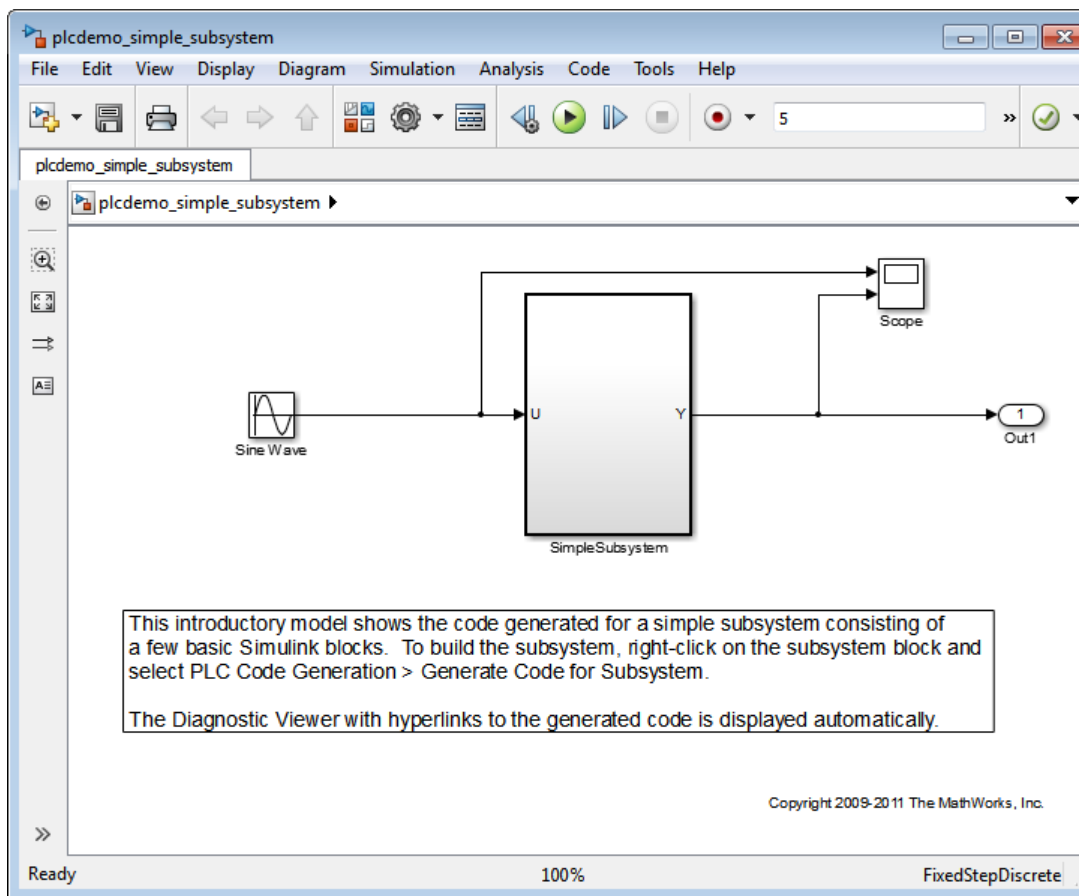

3 Right-click the Subsystem block and select **PLC Code > Options**.

The Configuration Parameters dialog box is displayed.

4 In **PLC Code > General options > Target IDE**, select your target IDE, for example, CoDeSys 2.3.

5 Select the **Generate testbench for subsystem** check box.

6 Click **Apply**.

7 Click the **Generate code** button.

This button:

- Generates structured text code (same as the **PLC Code > Generate Code for Subsystem** option)
- Generates the test bench for code through Simulink simulation
- Combines the generated code and test bench into *model_name.exp* (for example, *plcdemo_simple_subsystem.exp*)

When the code generation is complete, an information window is displayed.

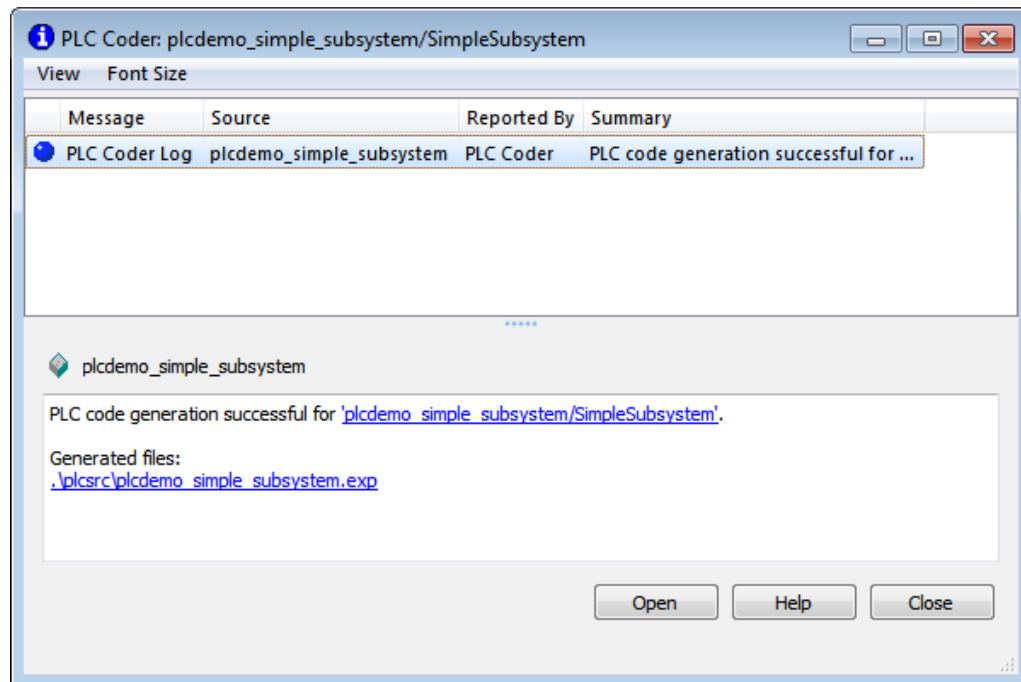

8 Click OK.

The Simulink PLC Coder software generates structured text code and writes it to *current_folder/plcsrc/plcdemo_simple_subsystem.exp*. Depending on the target IDE, the coder might generate additional supporting files.

- 9 Close the model.

```
bdclose(sys)
```

See the user manual for your target IDE for information on how to import generated code into the target IDE.

Import and Verify Structured Text Code Automatically

In this section...

“Import and Verify Structured Text to KW-Software MULTIPROG 5.0 and Phoenix Contact PC WORX 6.0 IDEs Automatically” on page 3-9

“Generate, Automatically Import, and Verify Structured Text” on page 3-11

These topics assume that you have read “Import Structured Text Code Automatically” on page 1-31. If you have not yet done so, read that topic first. It also assumes that you are confident that your model produces structured text that does not require visual examination.

If you do not want to run and verify the generated code and want only to import it, see “Generate and Automatically Import Structured Text Code” on page 1-32.

Import and Verify Structured Text to KW-Software MULTIPROG 5.0 and Phoenix Contact PC WORX 6.0 IDEs Automatically

Before you can automatically import generated code to this IDE, create an Empty template. This topic assumes that you have already set your target IDE to KW-Software MULTIPROG 5.0 or Phoenix Contact PC WORX 6.0.

- 1 Start the KW-Software MULTIPROG 5.0 or Phoenix Contact PC WORX 6.0 IDE.
- 2 Select **File > Delete Template** and search for and delete any template named Empty. Click **OK** when done.
- 3 Select **File > New Project**, select Project Wizard, then click **OK**.

The Project Wizard starts.

- a In the **Project Name** field, type Empty,
- b In the **Project Path** field, type or select a path to which you have write privileges.
- c Click **Next**.

- d In the remaining wizard dialog boxes, click **Next** to leave the default selections. At the end of the wizard, click **Finish**.

The IDE updates with the new Empty project tree.

- 4 In the project, delete everything under the following nodes:
 - Logical POU's
 - Physical Hardware
- 5 Check that the project tree has only top-level nodes for Libraries, Data Types, Logical POU's, and Physical Hardware. There should be no subtree nodes.
- 6 In the IDE, select **File > Save As Template**.
- 7 In **Template Name**, type Empty.
- 8 Click **OK**.
- 9 Close the IDE interface.

When you are ready, open your model, right-click the Subsystem block, and select one of the following:

- **PLC Code > Generate and Import Code for Subsystem**
- **PLC Code > Generate, Import, and Verify Code for Subsystem**

The coder:

- 1 Generates the code and test bench.
- 2 Starts the IDE.
- 3 Creates a new, empty project using your Empty template.
- 4 Imports the generated code and test bench in XML file to the IDE.
- 5 If you selected **PLC Code > Generate, Import, and Verify Code for Subsystem**, the IDE also runs the generated code to verify it.

Generate, Automatically Import, and Verify Structured Text

You can generate, automatically import, and run and verify structured text code. If you want only to generate and automatically import structured text code, see “Import Structured Text Code Automatically” on page 1-31 instead.

The following procedure assumes that you have installed your target PLC IDE in a default location. If you installed the target PLC IDE in a nondefault location, open the Configuration Parameters dialog box. In the PLC Coder node, set the **Target IDE Path** parameter to the installation folder of your PLC IDE. See “Target IDE Path” on page 12-6 for more details.

Note While the automatic import and verification process is in progress, do not touch your mouse or keyboard. Doing so might disrupt the automatic import or verification process. You can resume normal operations when the process completes.

If you are working with the KW-Software MULTIPROG 5.0 or Phoenix Contact PC WORX 6.0 IDE, see “Import and Verify Structured Text to KW-Software MULTIPROG 5.0 and Phoenix Contact PC WORX 6.0 IDEs Automatically” on page 3-9.

- 1** If you do not have the `plcdemo_simple_subsystem` model open, open it now.
- 2** Right-click the Subsystem block and select **PLC Code > Generate, Import, and Verify Code for Subsystem**.

The coder then:

- a** Generates the code and test bench.
- b** Starts the target IDE.
- c** Creates a new project.
- d** Imports the generated code and test bench to the new project in the target IDE.
- e** On the target IDE, runs the generated code to verify it.

Code Generation Reports

- “Information in Code Generation Reports” on page 4-2
- “Create and Use Code Generation Reports” on page 4-4

Information in Code Generation Reports

The coder creates and displays a Traceability Report file when you select one or more of these options:

GUI Option	Command-Line Property	Description
Generate traceability report	PLC_GenerateReport	Specify whether to create code generation report.
Generate model Web view	PLC_GenerateWebview	Include the model Web view in the code generation report to navigate between the code and model within the same window. You can share your model and generated code outside of the MATLAB environment.

In the Configuration Parameters dialog box, in the **Report** panel, you see these options.

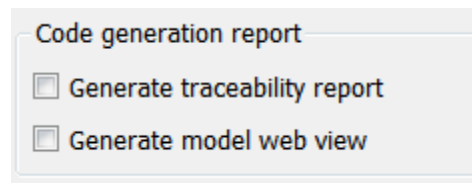

Note You must have a Simulink Report Generator™ license to generate traceability reports.

The coder provides the traceability report to help you navigate more easily between the generated code and your source model. When you enable code generation report, the coder creates and displays an HTML code generation report. You can generate reports from the Configuration Parameters dialog

box or the command line. A typical traceability report looks something like this figure:

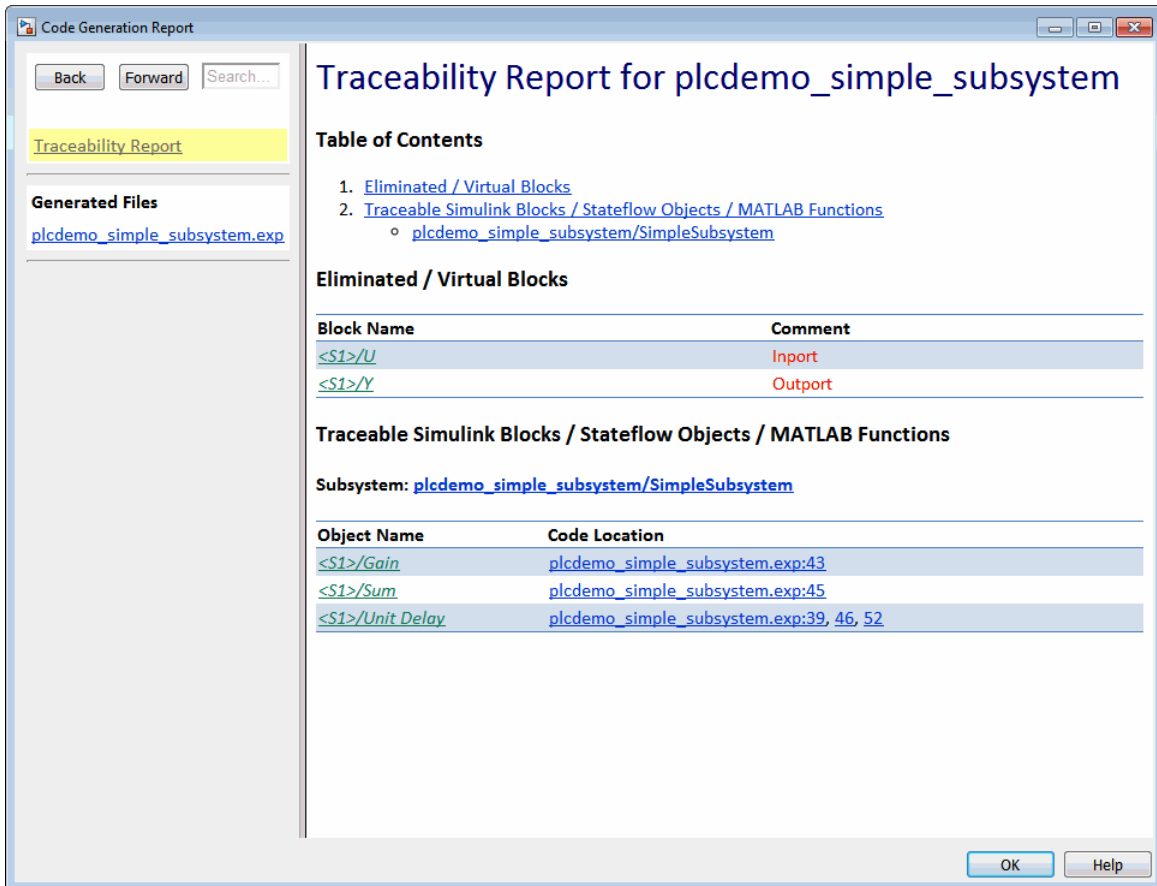

Create and Use Code Generation Reports

In this section...
“Generate a Traceability Report from Configuration Parameters” on page 4-4
“Keep the Report Current” on page 4-6
“Trace from Code to Model” on page 4-7
“Trace from Model to Code” on page 4-8
“Model Web View in Code Generation Report” on page 4-10
“Generate a Traceability Report from the Command Line” on page 4-13

Generate a Traceability Report from Configuration Parameters

To generate a Simulink PLC Coder code generation report from the Configuration Parameters dialog box:

- 1 Verify that the model is open.
- 2 Open the Configuration Parameters dialog box and navigate to the **PLC Code Generation** pane.
- 3 To enable report generation, select **Report > Generate traceability report**.
- 4 Click **Apply**.

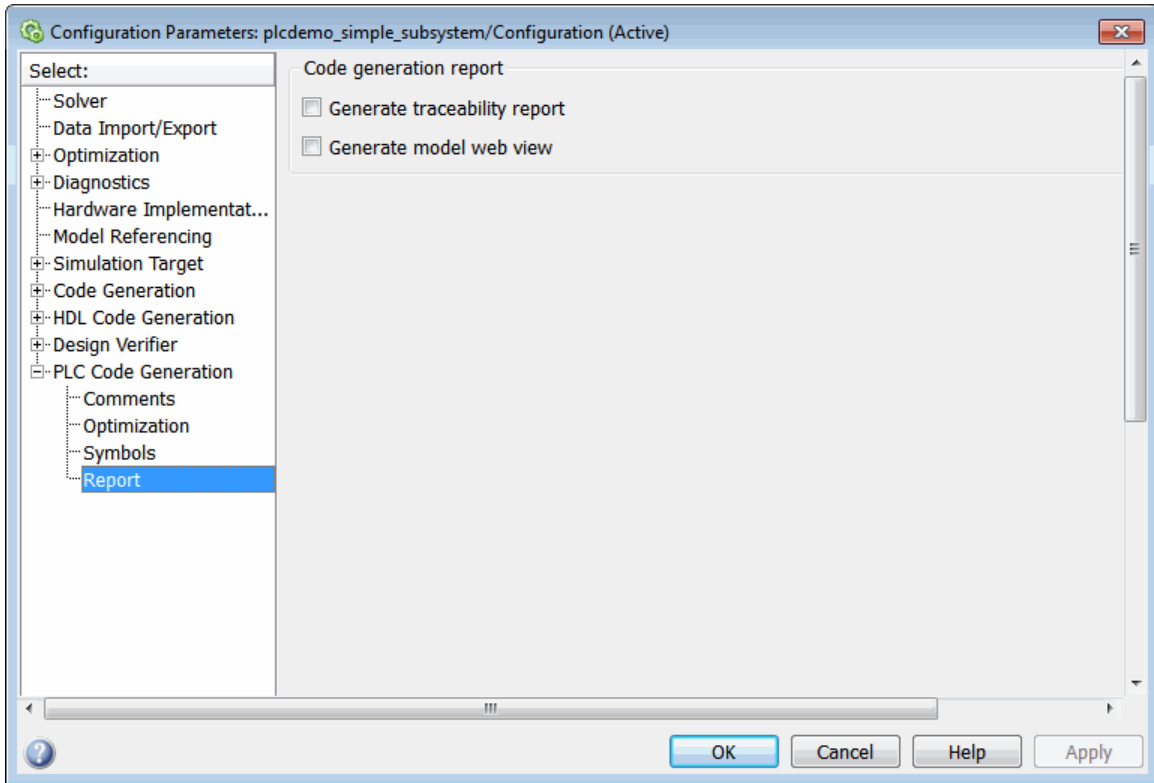

- 5 Click **PLC Code Generation > Generate code** to initiate code and report generation. The coder generates HTML report files as part of the code generation process.

The HTML report appears:

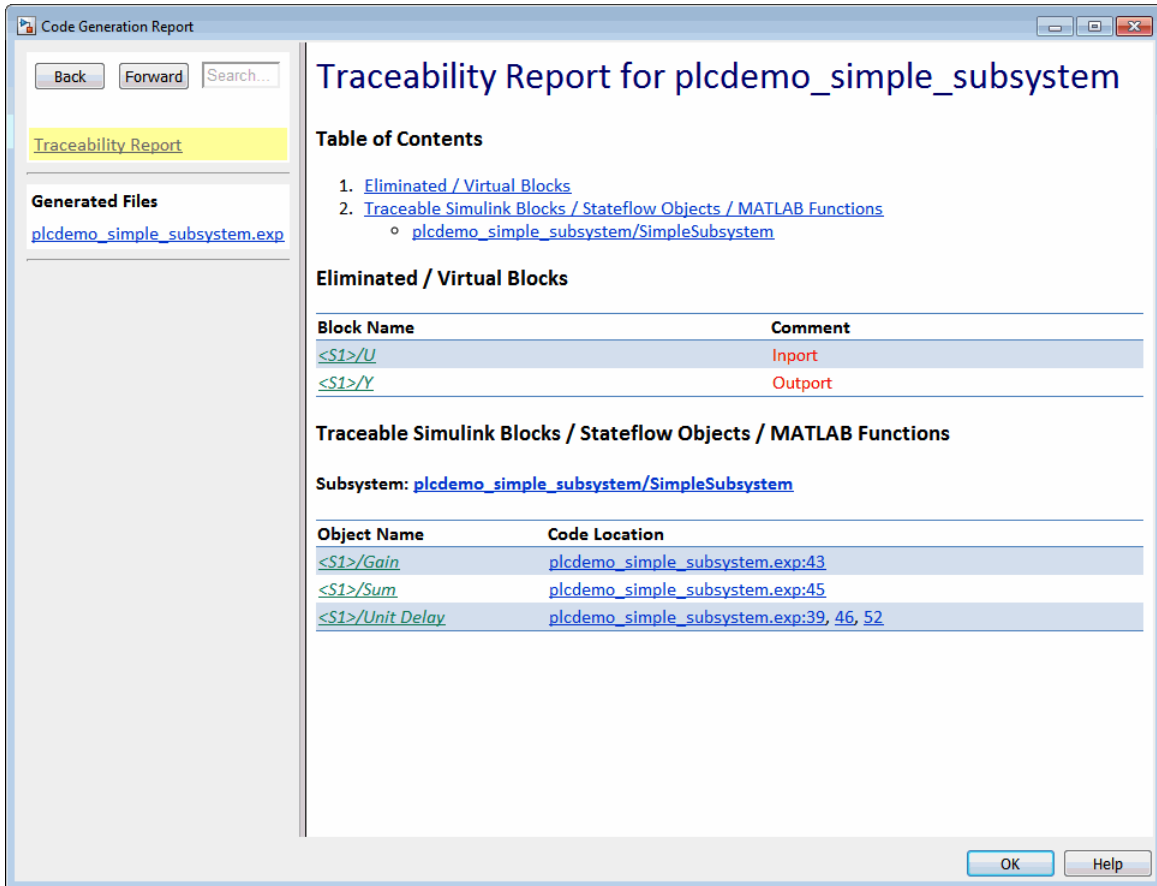

For more information on using the report that you generate for tracing, see:

- “Trace from Code to Model” on page 4-7
- “Trace from Model to Code” on page 4-8

Keep the Report Current

If you generate a code generation report for a model, and subsequently make changes to the model, the report might become invalid. To keep your code generation report current, after modifying the source model, regenerate code and the report. If you close and then reopen a model, regenerate the report.

Trace from Code to Model

You must have already generated code with a traceability report. If not, see “Generate a Traceability Report from Configuration Parameters” on page 4-4 or “Generate a Traceability Report from the Command Line” on page 4-13.

To trace generated code to your model:

- 1 In the generated code HTML report display, look for `<S1>/Gain`.

```

32  END_VAR
33  VAR_TEMP
34      rtb_Gain: LREAL;
35  END_VAR
36  CASE ssMethodType OF
37      SS_INITIALIZE:
38
39          (* InitializeConditions for UnitDelay: '<S1>/Unit Delay' *)
40          UnitDelay_DSTATE := 0.0;
41  SS_STEP:
42
43          (* Gain: '<S1>/Gain' incorporates:
44             * Import: '<Root>/U'
45             * Sum: '<S1>/Sum'
46             * UnitDelay: '<S1>/Unit Delay' *)
47          rtb_Gain := (U - UnitDelay_DSTATE) * 0.5;
48
49          (* Output: '<Root>/Y' *)
50          Y := rtb_Gain;
51
52          (* Update for UnitDelay: '<S1>/Unit Delay' *)
53          UnitDelay_DSTATE := rtb_Gain;
54  END_CASE;
55  END_FUNCTION_BLOCK

```

S1/Gain

- 2 In the HTML report window, click a link to highlight the corresponding source block. For example, in the HTML report shown in the previous figure, you click the hyperlink for the Gain block (highlighted) to view that block in the model. Clicking the hyperlink locates and displays the

corresponding block in the model editor window. You can use the same method to trace other block from the HTML report.

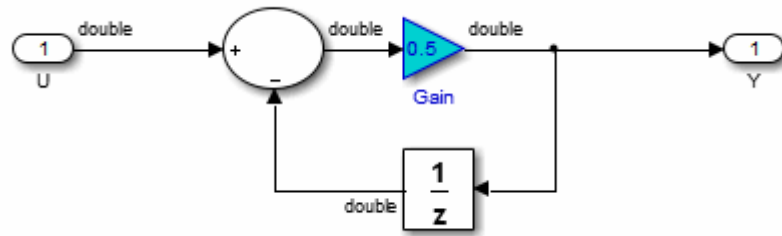

Trace from Model to Code

You can select a component at any level of the model with model-to-code traceability. You can also view the code references to that component in the HTML code generation report. You can select the following objects for tracing:

- Subsystem
- Simulink block
- MATLAB Function block
- Truth Table block
- State Transition Table block
- Stateflow chart, or the following elements of a Stateflow chart:
 - State
 - Transition
 - Graphical function
 - MATLAB function
 - Truth table function

You must have already generated code with a traceability report to trace a model component to the generated code. If not, see “Generate a Traceability Report from Configuration Parameters” on page 4-4 or “Generate a Traceability Report from the Command Line” on page 4-13.

To trace a model component to the generated code:

- 1 In the model window, right-click the component and select **PLC Code > Navigate to Code**.

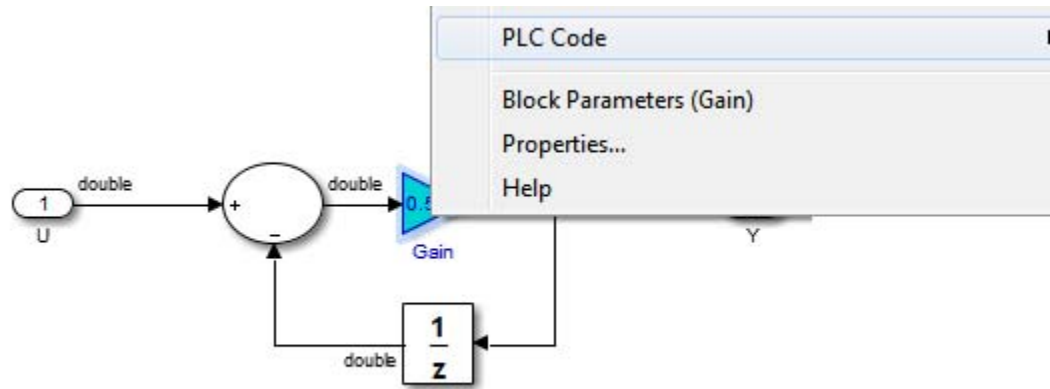

- 2 Selecting **Navigate to Code** activates the HTML code generation report. The following figure shows the result of tracing the Gain block within the subsystem.

```

40         UnitDelay_DSTATE := 0.0;
41     SS_STEP:
42
43     (* Gain: '<S1>/Gain' incorporates:
44        * Inport: '<Root>/U'
45        * Sum: '<S1>/Sum'
46        * UnitDelay: '<S1>/Unit Delay' *)
47     rtb_Gain := (U - UnitDelay_DSTATE) * 0.5;
48

```

In the report, the highlighted tag S1/Gain indicates the beginning of the generated code for the block. You can use the same method to trace from other Simulink, Stateflow and MATLAB objects to the generated traceability report.

Model Web View in Code Generation Report

Model Web Views

To review and analyze the generated code, it is helpful to navigate between the code and model. You can include a Web view of the model within the HTML code generation report. You can then share your model and generated code outside of the MATLAB environment. You need a Simulink Report Generator license to include a Web view of the model in the code generation report.

Browser Requirements for Web Views

Web views require a Web browser that supports Scalable Vector Graphics (SVG). Web views use SVG to render and navigate models.

You can use the following Web browsers:

- Mozilla® Firefox® Version 1.5 or later, which has native support for SVG. To download the Firefox browser, go to www.mozilla.com/.
- Apple Safari Web browser
- The Microsoft® Internet Explorer® Web browser with the Adobe® SVG Viewer plug-in. To download the Adobe SVG Viewer plug-in, go to www.adobe.com/svg/.

Note Web views do not currently support Microsoft Internet Explorer 9.

Generate HTML Code Generation Report with Model Web View

This example shows how to create an HTML code generation report which includes a Web view of the model diagram.

- 1 Open the `plcdemo_simple_subsystem` model.
- 2 Open the Configuration Parameters dialog box and navigate to the Code Generation pane.
- 3 To enable report generation, select **Report > Create report code generation report**.

- 4 To enable model web view, select **Report > Generate model Web view**.
- 5 Click **Apply**.

The dialog box looks something like this:

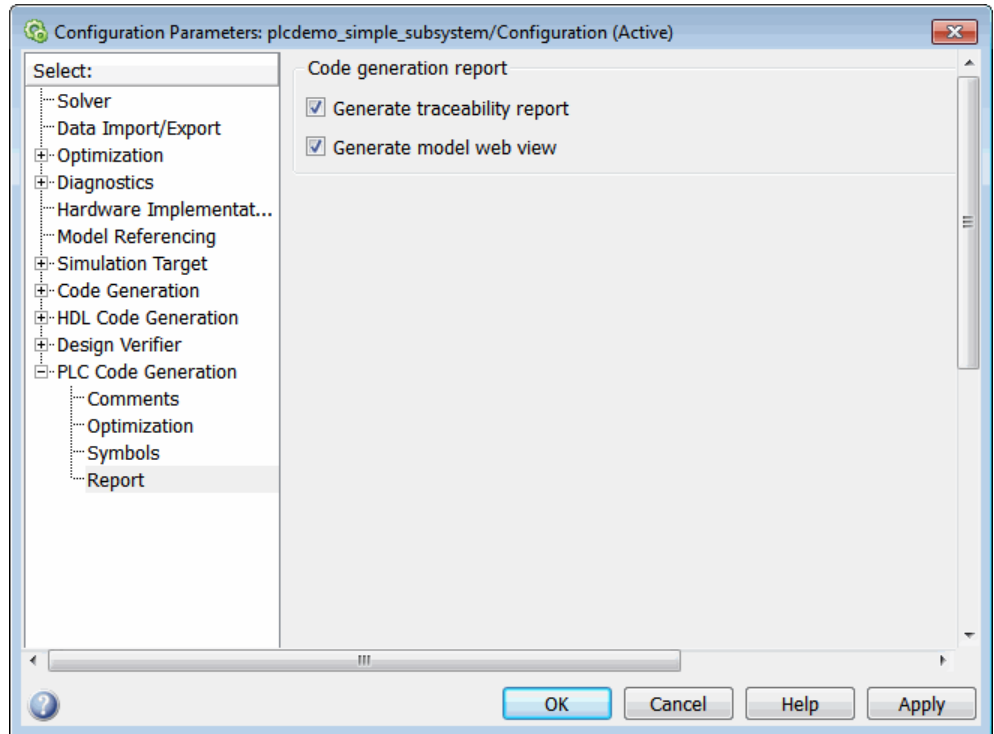

- 6 Click **PLC Code Generation > Generate code** to initiate code and report generation. The code generation report for the top model opens in a MATLAB Web browser.

Code Generation Report

Back Forward Search...

Traceability Report

Generated Files

[plcdemo_simple_subsystem.exp](#)

Traceability Report for plcdemo_simple_subsystem

Table of Contents

- [Eliminated / Virtual Blocks](#)
- [Traceable Simulink Blocks / Stateflow Objects / MATLAB Functions](#)
 - [plcdemo_simple_subsystem/SimpleSubsystem](#)

Eliminated / Virtual Blocks

Block Name	Comment
<S1>/U	Import
<S1>/Y	Outport

Simulink Root

plcdemo_simple_

SimpleSubsys

SimpleSubsystem

Block diagram showing a Simulink model with an input 'U' (double) entering a summing junction, followed by a gain block '0.5', a feedback loop with a '1/Z' block, and an output 'Y' (double).

OK Help

- In the left navigation pane, select a source code file. The corresponding traceable source code is displayed in the right pane and includes hyperlinks.
- Click a link in the code. The model Web view displays and highlights the corresponding block in the model.
- To go back to the code generation report for the top model, at the top of the left navigation pane, click the Back button until the top model's report is displayed.

For more information about navigating between the generated code and the model diagram, see:

- “Trace from Code to Model” on page 4-7
- “Trace from Model to Code” on page 4-8

Model Web View Limitations

When you are using the model Web view, the HTML code generation report includes the following limitations :

- Code is not generated for virtual blocks. In the model Web view, if you click a virtual block, the code generation report clears any highlighting in the source code files.
- Stateflow truth tables, events, and links to library charts are not supported in the model Web view.
- Searching in the code generation report does not find or highlight text in the model Web view.
- In a subsystem build, the traceability hyperlinks of the root-level inports and outports blocks are disabled.
- If you navigate from the actual model diagram (not the model Web view in the report), to the source code in the HTML code generation report, the model Web view is disabled and is no longer visible. To enable the model Web view, open the report again, see .

Generate a Traceability Report from the Command Line

To generate a Simulink PLC Coder code generation report from the command line code for the subsystem, `plcdemo_simple_subsystem/SimpleSubsystem`:

- 1 Open a Simulink PLC Coder model, for example:

```
open_system('plcdemo_simple_subsystem');
```

- 2 Enable the code generation parameter `PLC_GenerateReport`. To view the output in the model Web view, also enable `PLC_GenerateWebview`:

```
set_param('plcdemo_simple_subsystem', 'PLC_GenerateReport', 'on');
```

```
set_param('plcdemo_simple_subsystem', 'PLC_GenerateWebView', 'on');
```

3 Generate the code.

```
generatedfiles = plcgeneratecode('plcdemo_simple_subsystem/SimpleSubsystem')
```

An information window and the traceability report are displayed. If the model Web view is also enabled, that view is displayed.

Working with Tunable Parameters in the Simulink PLC Coder Environment

- “Configure Tunable Parameters for Your Model” on page 5-2
- “Identify Tunable Parameters” on page 5-8
- “Tune Parameters Using Simulink.Parameter Objects” on page 5-12
- “Configure Tunable Parameters Using Configuration Parameters” on page 5-17

Configure Tunable Parameters for Your Model

In this section...
“Tunable Parameters” on page 5-2
“Configure Your Model for Tunable Parameters” on page 5-5

Tunable Parameters

Block parameters can be either tunable or nontunable. A tunable parameter is a parameter that you can change while a simulation is running. With the Simulink PLC Coder software, you can tune parameters:

- From the MATLAB workspace, while the model simulation is running.
- In the IDE, while the generated code is running.

The Simulink PLC Coder software exports tunable parameters as exported symbols and preserves the names of these parameters in the generated code. It does not mangle these names. As a result, if you use a reserved IDE keyword as a tunable parameter name, the code generation might cause compilation errors in the IDE. As a general rule, do not use IDE keywords as tunable parameter names.

The coder maps tunable parameters in the generated code as listed in the following table:

Target IDE	Parameter Storage Class			
	SimulinkGlobal	ExportedGlobal	ImportedExtern	Imported-ExternPointer
CoDeSys 2.3	Local function block variables.	Global variable.	Variable definition is skipped.	Ignored. If you set the parameter to this value, the software treats

Target IDE	Parameter Storage Class			
	SimulinkGlobal	ExportedGlobal	ImportedExtern	Imported-ExternPointer
				it the same as ImportedExtern.
CoDeSys 3.3	Local function block variables.	Global variable.	Variable definition is skipped.	Ignored. If you set the parameter to this value, the software treats it the same as ImportedExtern.
B&R Automation Studio 3.0	Local function block variable.	Local function block variable	Local function block variable.	Ignored. If you set the parameter to this value, the software treats it the same as ImportedExtern.
Beckhoff TwinCAT 2.11	Local function block variable.	Global variable.	Variable definition is skipped.	Ignored. If you set the parameter to this value, the software treats it the same as ImportedExtern.
KW-Software MULTIPROG 5.0	Local function block variable.	Local function block variable.	Local function block variable.	Ignored. If you set the parameter to this value, the software treats it the same as ImportedExtern.
Phoenix Contact PC WORX 6.0	Local function block variable.	Global variable.	Variable definition is skipped.	Ignored. If you set the parameter to this value, the software treats it the same as ImportedExtern.

Target IDE	Parameter Storage Class			
	SimulinkGlobal	ExportedGlobal	ImportedExtern	Imported-ExternPointer
RSLogix 5000 17, 18: AOI	AOI local tags.	AOI input tags.	AOI input tags.	Ignored. If you set the parameter to this value, the software treats it the same as ImportedExtern.
RSLogix 5000 17, 18: Routine	Instance fields of program UDT tags.	Program tags.	Variable definition is skipped.	Ignored. If you set the parameter to this value, the software treats it the same as ImportedExtern.
Siemens SIMATIC STEP 7 5.4	Local function block variable.	Local function block variable.	Local function block variable.	Ignored. If you set the parameter to this value, the software treats it the same as ImportedExtern.
Generic	Local function block variable.	Global variable.	Variable definition is skipped.	Ignored. If you set the parameter to this value, the software treats it the same as ImportedExtern.
PLCOpen	Local function block variable.	Global variable.	Variable definition is skipped.	Ignored. If you set the parameter to this value, the software treats it the same as ImportedExtern.

Configure Your Model for Tunable Parameters

Simulink PLC Coder parameters are inlined and not tunable by default.

To configure a model to enable tunable parameters is:

- 1 Identify the model parameters that you want to be tunable.
- 2 Define these parameters in the MATLAB workspace in one of the following ways:
 - Create a `Simulink.Parameter` object and use either the `Simulink.Parameter` command-line interface or Model Explorer to configure parameters.

Simulink stores `Simulink.Parameter` objects outside the model. This action enables you to share `Simulink.Parameter` objects between multiple models and work with referenced models.

- Use the Configuration Parameters dialog box to define parameters, then configure tunable parameters in the **Configuration Parameters > Optimization > Signals and Parameters > Model Parameter Configuration** dialog box.

Simulink stores specified global tunable parameters using the Configuration Parameters dialog box with the model. You specify these parameter values in the MATLAB base workspace. You cannot share these parameters between multiple models.

This table lists the possible tunable parameters and how you can set them using either `Simulink.Parameter` or the Configuration Parameters dialog box. When using `Simulink.Parameter`, enter the entire command without hyphens.

Mapping of Tunable Parameters in Generated Code	Simulink.Parameter	Configuration Parameter Dialog Box
Local variables in function block	<pre>Simulink.Parameter.- StorageClass = `SimulinkGlobal'</pre>	<p>Set Configuration Parameters > Optimization- > Signals and Parameters > Model Parameter Configuration > Storage class to SimulinkGlobal (Auto)</p>
Global variables	<pre>Simulink.Parameter.- StorageClass = 'ExportedGlobal' Simulink.Parameter.- CoderInfo.CustomStorageClass = 'Default'</pre>	<p>Set Configuration Parameters > Optimization- > Signals and Parameters > Model Parameter Configuration > Storage class to ExportedGlobal</p> <p>Set Configuration Parameters > Optimization- > Signals and Parameters > Model Parameter Configuration > Storage type qualifier to empty field (default)</p>
Global constants	<pre>Simulink.Parameter.Storage- Class = 'ExportedGlobal' Simulink.Parameter.- CoderInfo.CustomStorageClass = 'Const'</pre>	<p>Set Configuration Parameters > Optimization- > Signals and Parameters > Model Parameter Configuration > Storage class to ExportedGlobal</p> <p>Set Configuration Parameters > Optimization- > Signals and Parameters > Model Parameter</p>

Mapping of Tunable Parameters in Generated Code	Simulink.Parameter	Configuration Parameter Dialog Box
		Configuration > Storage type qualifier to const
Externally defined variable	Simulink.Parameter.- StorageClass = 'ImportedExtern'	Set Configuration Parameters > Optimization-> Signals and Parameters > Model Parameter Configuration > Storage class to ImportedExtern

Identify Tunable Parameters

The model `my_plcdemo_tunable_params` shows how to configure tunable parameters. This model is the same as the `plcdemo_tunable_params` and `plcdemo_tunable_params_slparamobj` example models. The difference is that the example model already has the tunable parameters configured.

Note The coder does not support tuning parameters of bus data type.

- 1 In the MATLAB Command Window, create a model to look like the following.

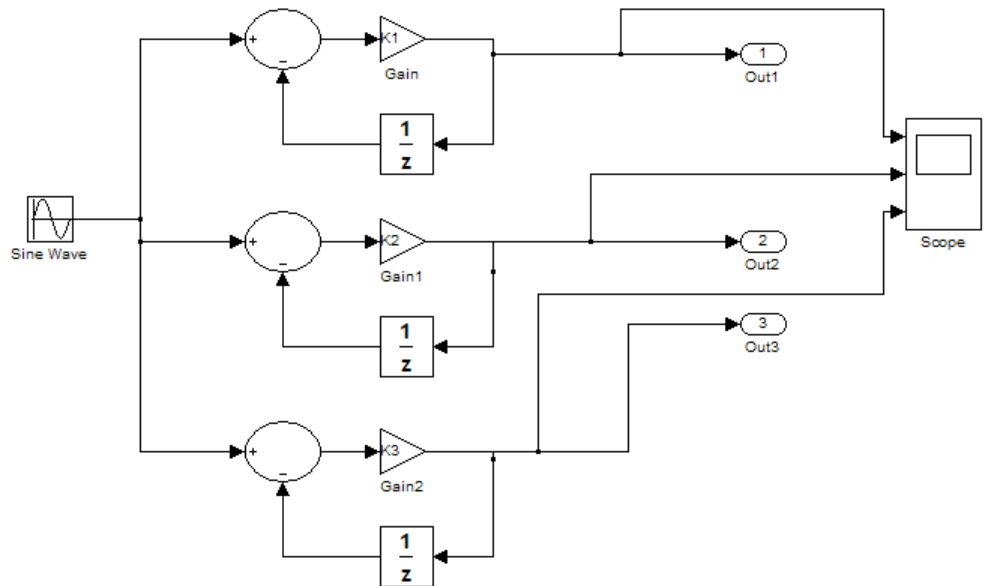

- 2 Select the Sum, Gain, and Unit Delay blocks and create an atomic subsystem with inputs U, U1, and U2 and outputs Y, Y1, and Y2. Rename the Subsystem block as SimpleSubsystem. When you are finished, the top model and atomic subsystem model look like the following model:

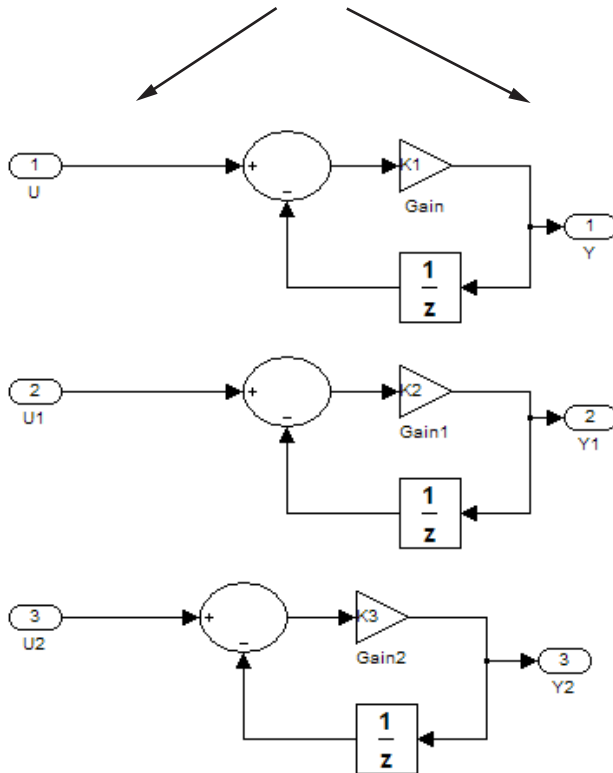
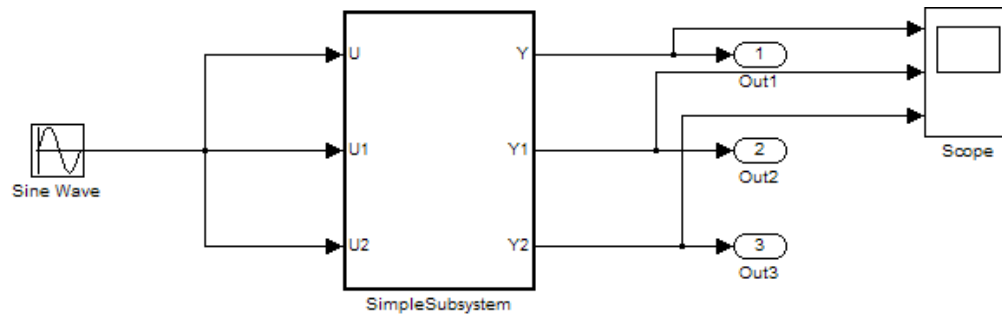

3 Save this subsystem as my_plcdemo_tunable_params.

4 Double-click SimpleSubsystem.

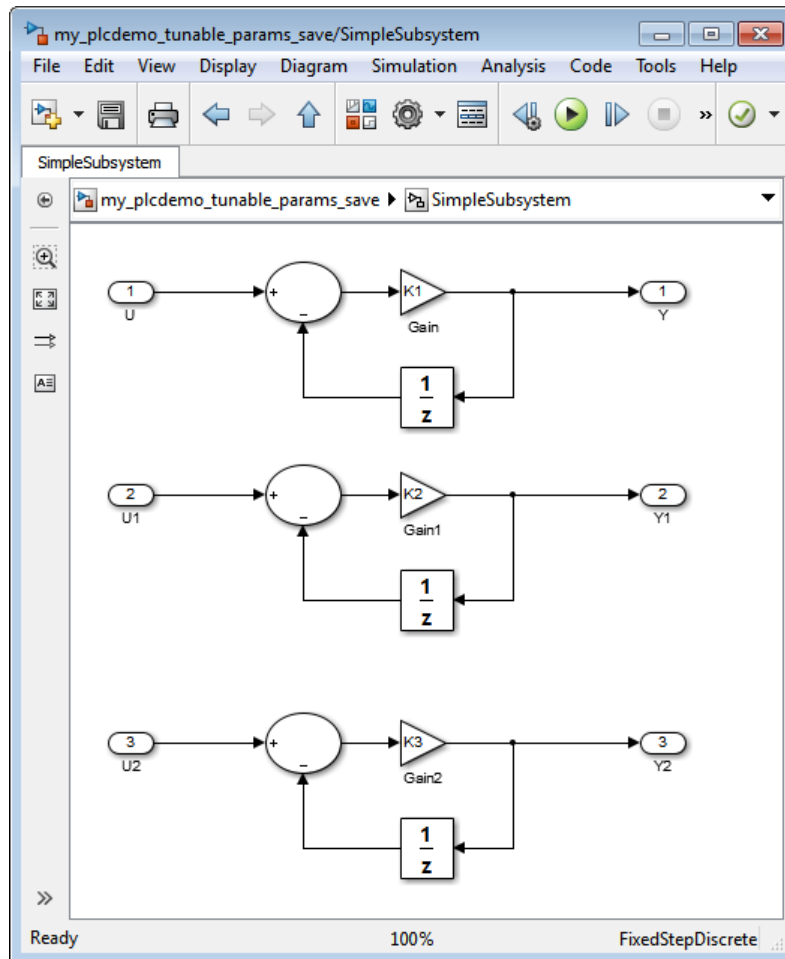

5 The three Gain blocks have the constants that you want to make tunable: $K1$, $K2$, and $K3$.

Next, define these parameters in the MATLAB workspace.

- If you want to use `Simulink.Parameter` objects, and use either the `Simulink.Parameter` command-line interface or Model Explorer to configure parameters, see “Tune Parameters Using `Simulink.Parameter` Objects” on page 5-12.

- If you want to use the Configuration Parameters dialog box, see “Defining Tunable Parameter Values in the MATLAB Workspace” on page 5-17. Use the Configuration Parameters dialog box to define parameters, then configure tunable parameters in the **Configuration Parameters > Optimization > Signals and Parameters > Model Parameter Configuration** dialog box.

Tune Parameters Using Simulink.Parameter Objects

In this section...

“Work Directly with Simulink.Parameter Objects” on page 5-12

“Work with Simulink.Parameter Objects Using Model Explorer” on page 5-15

Work Directly with Simulink.Parameter Objects

This topic describes how to define tunable parameters in the MATLAB workspace using a MATLAB script that works with `Simulink.Parameter` objects.

Note Alternatively, you can use the Model Explorer to create constants as `Simulink.Parameter` and define them. For more information, see “Work with Simulink.Parameter Objects Using Model Explorer” on page 5-15.

You must have already created the `my_plcdemo_tunable_params` model or opened `plcdemo_tunable_params` or `plcdemo_tunable_params_slparamobj` and identified the parameters for tuning. If you have not yet done so, see “Identify Tunable Parameters” on page 5-8.

- 1 In the MATLAB base workspace, create a script that defines tunable parameters. In the MATLAB Command Window, create a MATLAB file, such as `setup_tunable_params.m`, that contains the following code. This script creates the constants `K1`, `K2`, and `K3` as `Simulink.Parameter` objects, assigns values, and sets the storage class for these constants.

```
% define tunable parameters in base workspace as
% Simulink.Parameter objects

% tunable parameter mapped to local variable
K1 = Simulink.Parameter;
K1.Value = 0.1;
K1.StorageClass = 'SimulinkGlobal';
```



```
% tunable parameter mapped to global variable
K2 = Simulink.Parameter;
K2.Value = 0.2;
K2.StorageClass = 'ExportedGlobal';
K2.CoderInfo.CustomStorageClass = 'Default';

% tunable parameter mapped to global const
K3 = Simulink.Parameter;
K3.Value = 0.3;
K3.StorageClass = 'ExportedGlobal';
K3.CoderInfo.CustomStorageClass = 'Const';
```

- 2** In the my_plcdemo_tunable_params model, select **File > Model Properties > Model Properties**.
- 3** In the Model Properties dialog box, on the **Callbacks** pane, select **PreLoadFcn**.
- 4** To run the script at model load time, enter the name of the script that you created, for example, **setup_tunable_params**.

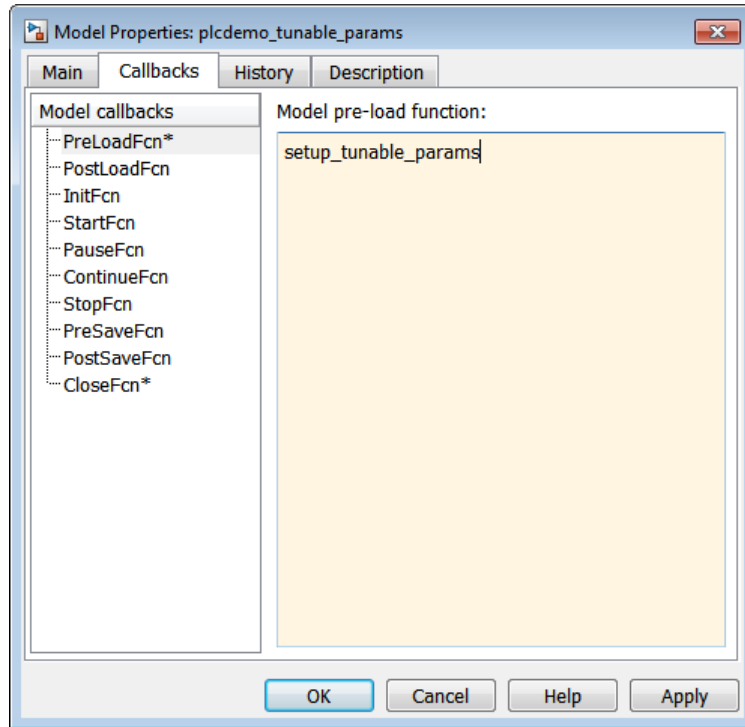

5 Click **Apply**.

6 In the **Callbacks** pane, select **CloseFcn**.

7 In the **Model close function** pane, enter the clear command to clear these constants. For example:

```
clear K1 K2 K3;
```

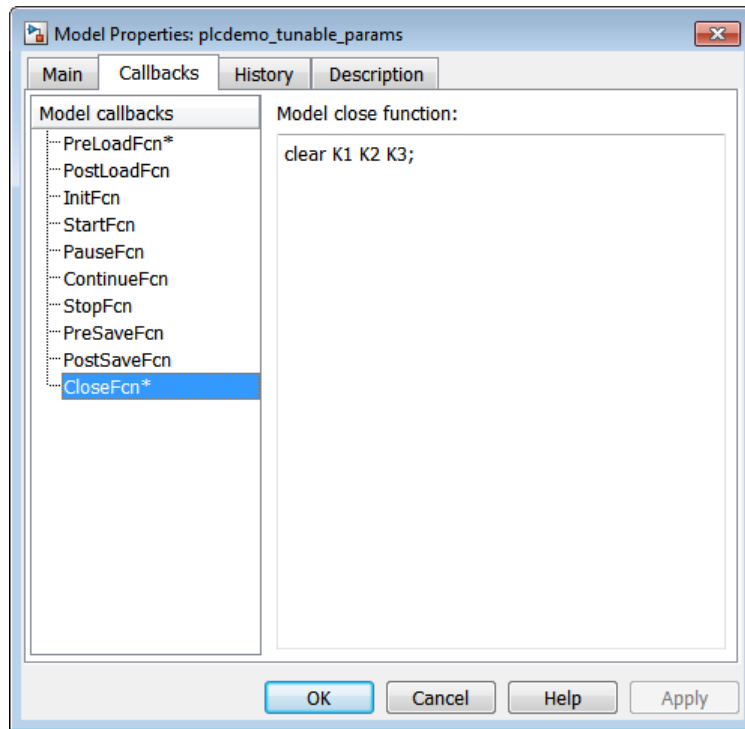

When you close the model, this command clears these constants from the MATLAB workspace.

- 8 Click **Apply**, then **OK**.
- 9 In the MATLAB Command Window, you can change the parameter values using the `Simulink.Parameter.Value` field.
- 10 When you are done, save the model, and generate and inspect the code.

Work with Simulink.Parameter Objects Using Model Explorer

This topic describes how to define tunable parameters in the MATLAB workspace using the Model Explorer. Within the Model Explorer, you can create constants as `Simulink.Parameter` objects and tune the parameters.

Note Alternatively, you can use the `Simulink.Parameter` object command-line interface to create constants and define them. For more information, see “Work Directly with `Simulink.Parameter` Objects” on page 5-12.

- 1 In the Simulink editor window, select **View > Model Explorer**.

In the MATLAB Command Window, create a MATLAB file, such as `setup_tunable_params.m`, that contains the following code. This script creates the constants `K1`, `K2`, and `K3` as `Simulink.Parameter` objects, assigns values, and sets the storage class for these constants.

- 2 In the **Model Hierarchy** pane, select **Base Workspace**.

The **Contents** pane is updated with the contents of the MATLAB base workspace.

- 3 To create a new `Simulink.Parameter` object, select **Add > Simulink Parameter**.

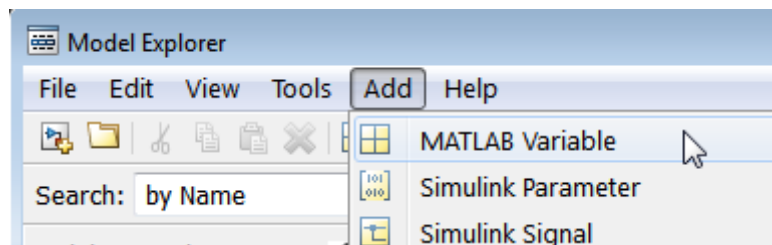

- 4 In the **Dialog** pane for the `Simulink.Parameter` object, edit the **Storage class** and **Value** parameters. Click **Apply** to save changes.

- 5 When you are done, save the model, and generate and inspect the code.

For more information about using the Model Explorer to work with data objects, see “Using the Model Explorer to Create Data Objects”.

Configure Tunable Parameters Using Configuration Parameters

In this section...

“Defining Tunable Parameter Values in the MATLAB Workspace” on page 5-17

“Configuring Parameters to Be Tunable” on page 5-19

Defining Tunable Parameter Values in the MATLAB Workspace

This topic describes how to define tunable parameter values in the MATLAB workspace using the Simulink Model Properties dialog box. Defining tunable parameters in this way enables the model to automatically define parameters each time that you open the model.

You must have already created the `my_plcdemo_tunable_params` model or opened `plcdemo_tunable_params` and identified the parameters for tuning. If you have not yet done so, see “Identify Tunable Parameters” on page 5-8.

- 1** In the `my_plcdemo_tunable_params` model, select **File > Model Properties > Model Properties**.
- 2** In the Model Properties dialog box, on the **Callbacks** pane, select `PreLoadFcn`.
- 3** In the **Model pre-load function** pane, enter the three constants $K1$, $K2$, and $K3$. Assign initial values to them. For example:

```
K1 = 0.1;
```

```
K2 = 0.2;
```

```
K3 = 0.3;
```

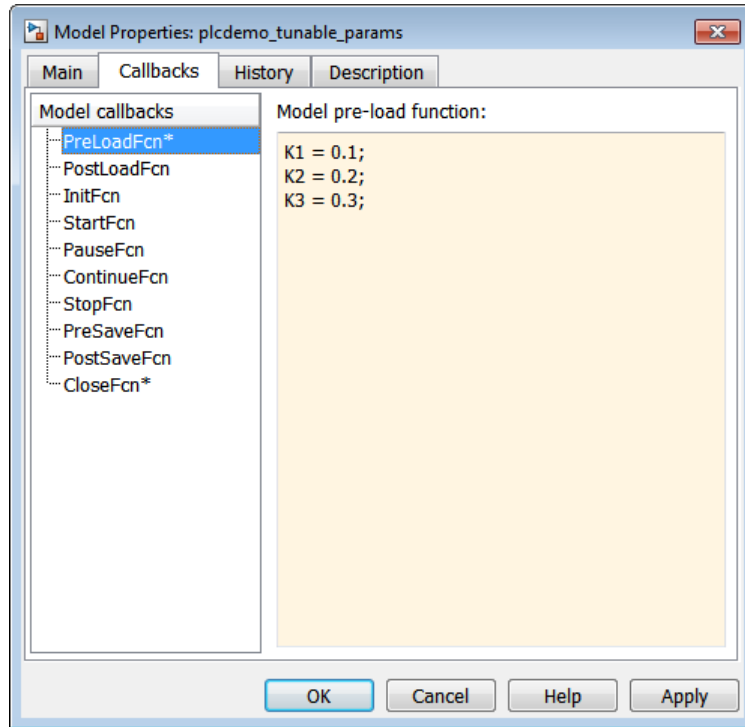

4 Click **Apply**.

5 In the **Callbacks** pane, select **CloseFcn**.

6 In the **Model close function** pane, enter the clear command to clear these constants. For example:

```
clear K1 K2 K3;
```

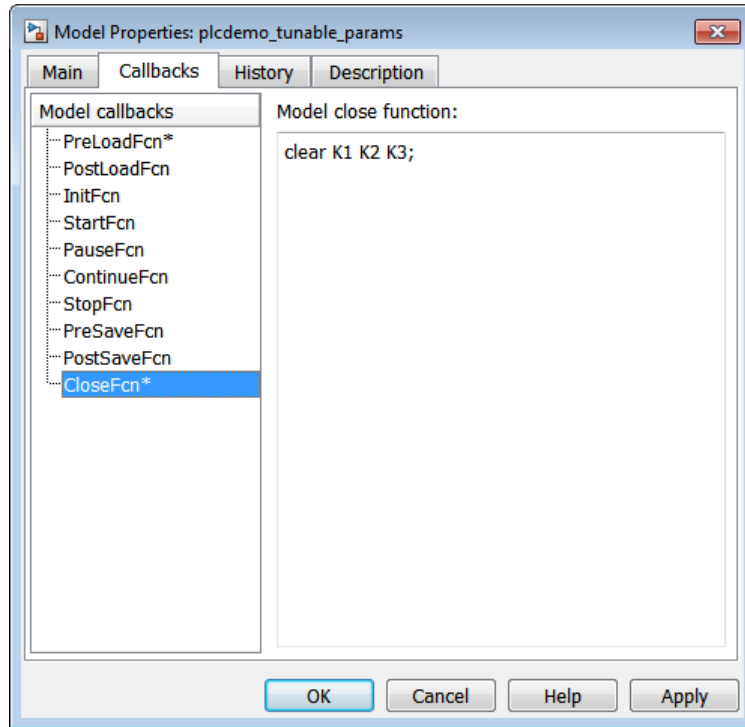

When you close the model, this command clears these constants from the MATLAB workspace.

7 Click **Apply**, then **OK**.

Your next task is to configure these parameters to be tunable. See “Configuring Parameters to Be Tunable” on page 5-19.

Configuring Parameters to Be Tunable

This topic describes how to configure parameters to be tunable using the Simulink Configuration Parameters dialog box.

You must have already created the `my_plcdemo_tunable_params` model or opened `plcdemo_tunable_params` and defined the parameters for tuning. If

you have not yet done so, see “Defining Tunable Parameter Values in the MATLAB Workspace” on page 5-17.

You must already be familiar with the tunable parameter properties on the **Global (tunable) parameters** pane. For more information, see *Setting Tunable Parameter Properties in the Simulink Coder™* documentation.

This example uses code generated with CoDeSys Version 2.3.

- 1** In the model, right-click SimpleSubsystem and select **PLC Code > Options**.
- 2** Navigate to **Optimization > Signals and Parameters**.
- 3** In the **Simulation and code generation** section, select the **Inline parameters** check box. (This check box is cleared by default.)

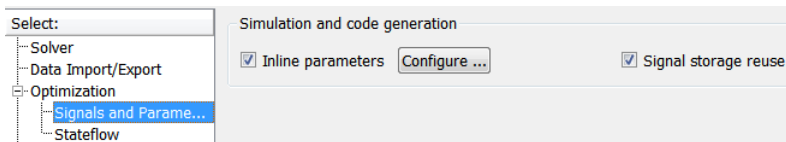

- 4** Click **Configure**.

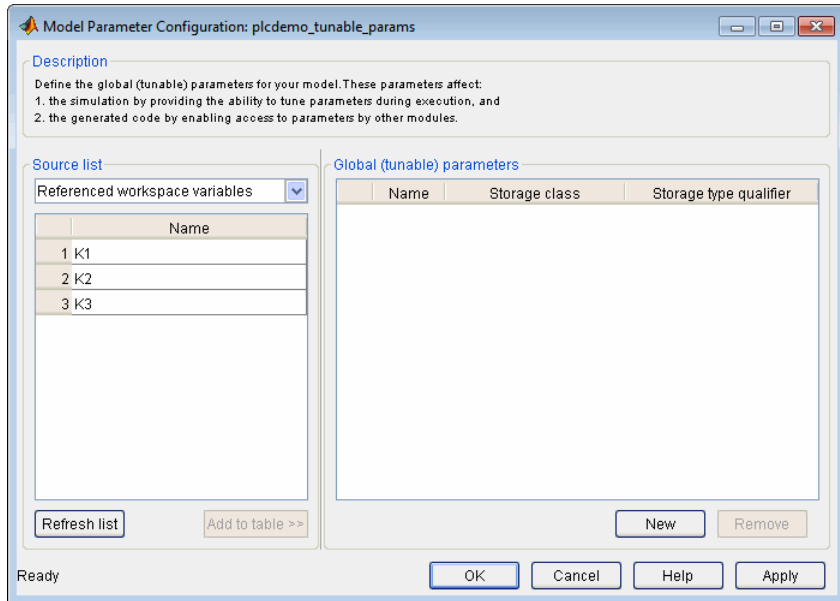

- 5 In the Model Parameter Configuration dialog box, from the **Source list**, select **Referenced workspace variables**.
- 6 Use the **Ctrl** key to select all the parameters and click **Add to table >>** to add them to the **Global (tunable) parameters** table.

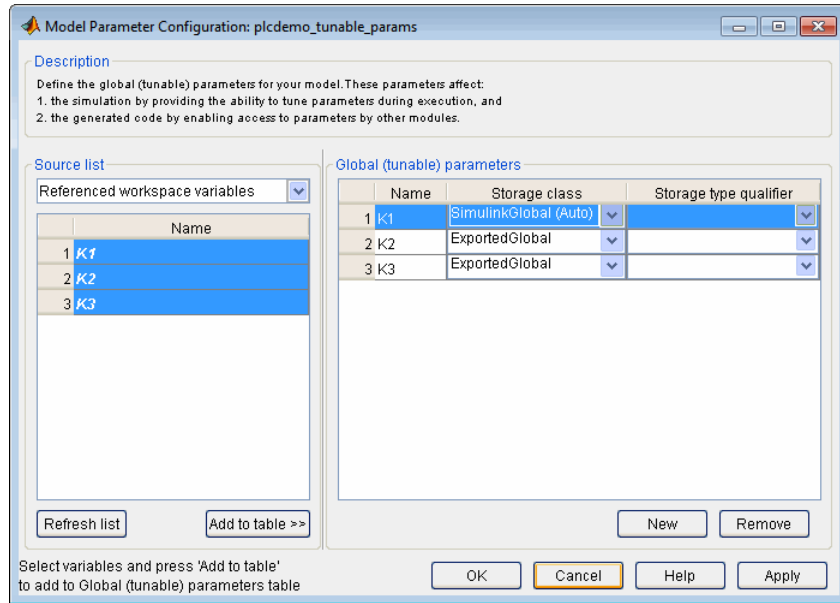

By default, this dialog box sets all parameters to the `SimulinkGlobal (Auto)` storage class. This setting generates code with the tunable parameters set at the local level. In this case, these parameters appear at the function block level in each function block that uses the parameter.

You can also optionally set the storage type qualifier for a parameter to `const`.

- 7** Click **Apply** and **OK**.
- 8** In the Configuration Parameters dialog box, navigate to **PLC Code > General options**.
- 9** Select the **Target IDE** and **Output Directory** settings, then click **Generate code**.
- 10** Observe that the VAR section of Function Block `SimpleSubsystem` defines `K1`, `K2`, and `K3`.

```

FUNCTION_BLOCK SimpleSubsystem
VAR_INPUT
    ssMethodType: SINT;
    U: LREAL;
    U1: LREAL;
    U2: LREAL;
END_VAR
VAR_OUTPUT
    Y: LREAL;
    Y1: LREAL;
    Y2: LREAL;
END_VAR
VAR
    K1: LREAL := 0.1;
    UnitDelay_DSTATE: LREAL;
    UnitDelay1_DSTATE: LREAL;
    UnitDelay2_DSTATE: LREAL;
END_VAR

```

- 11** To configure a parameter to be a global variable in the generated code, set the parameter storage class of *K2* to `ExportedGlobal`. Leave the storage type qualifier unset.

Some target IDEs do not support the access of global variables. In this case, the Simulink PLC Coder software uses `SimulinkGlobal` as the automatic storage class.

To configure a parameter to be a global constant in the generated code, set the parameter storage class of *K3* to `ExportedGlobal`. Set storage type qualifier to `const`.

- 12** Click **Apply** and **OK**, then rebuild the code.
- 13** Observe that *K2* is now in the `VAR_GLOBAL` section. *K3* is in the `VAR_GLOBAL_CONSTANT` section.

```
VAR_GLOBAL CONSTANT
    SS_INITIALIZE: SINT := 0;
    K3: LREAL := 0.3;
    SS_STEP: SINT := 1;
END_VAR
VAR_GLOBAL
    K2: LREAL := 0.2;
END_VAR
```

- 14** To configure a parameter so that you or somebody else can provide it through external structured text, set the parameter storage class of *K1* to `ImportedExtern`. The coder does not generate a variable declaration for the parameter in the code. Leave the storage type qualifier unset.
- 15** Click **Apply** and **OK**, then rebuild the code.
- 16** Observe that *K1* no longer appears in the VAR section of the generated code. (Compare to Step 10.)

```
VAR
    UnitDelay_DSTATE: LREAL;
    UnitDelay1_DSTATE: LREAL;
    UnitDelay2_DSTATE: LREAL;
END_VAR
```

Note The Simulink PLC Coder software does not support setting the parameter storage class to `ImportedExternPointer`. If you set the parameter to this value, the software treats it the same as `ImportedExtern`.

Controlling Generated Code Partitions

Function Block Partitions

In this section...
“Function Block Partitioning Guidelines” on page 6-2
“One Function Block for Atomic Subsystems” on page 6-2
“One Function Block for Virtual Subsystems” on page 6-3
“Multiple Function Blocks for Nonvirtual Subsystems” on page 6-4
“Control Generated Code Using Subsystem Block Parameters” on page 6-5

Function Block Partitioning Guidelines

The Simulink PLC Coder software converts subsystems to function block units according to the following rules:

- Generates a function block for the top-level atomic subsystem for which you generate code.
- Generates a function block for an atomic subsystem whose **Function packaging** parameter is set to **Function** or **Reusable function**.
- Inlines generated code from atomic subsystems, whose **Function packaging** parameter is set to **Inline**, into the function block that corresponds to the nearest ancestor subsystem. This nearest ancestor cannot be inlined.

These topics use code generated with CoDeSys Version 2.3.

One Function Block for Atomic Subsystems

The code for `plcdemo_simple_subsystem` is an example of generating code with one function block. The atomic subsystem for which you generate code does not contain any other subsystems.

```

FUNCTION_BLOCK SimpleSubsystem
VAR_INPUT
    ssMethodType: SINT;
    U: LREAL;
END_VAR
VAR_OUTPUT
    Y: LREAL;
END_VAR
VAR
    UnitDelay_DSTATE: LREAL;
END_VAR
VAR_TEMP
    rtb_Gain: LREAL;
END_VAR
CASE ssMethodType OF
    SS_INITIALIZE:
        (* InitializeConditions for UnitDelay: '<S1>/Unit Delay' *)
        UnitDelay_DSTATE := 0.0;
    SS_STEP:
        (* Gain: '<S1>/Gain' incorporates:
        * Inport: '<Root>/U'
        * Sum: '<S1>/Sum'
        * UnitDelay: '<S1>/Unit Delay' *)
        rtb_Gain := (U - UnitDelay_DSTATE) * 0.5;

        (* Outport: '<Root>/Y' *)
        Y := rtb_Gain;

        (* Update for UnitDelay: '<S1>/Unit Delay' *)
        UnitDelay_DSTATE := rtb_Gain;
END_CASE;
END_FUNCTION_BLOCK

```

One Function Block for Virtual Subsystems

The `plcdemo_hierarchical_virtual_subsystem` example contains an atomic subsystem that has two virtual subsystems, S1 and S2, inlined. A virtual subsystem does not have the **Treat as atomic unit** parameter selected. When you generate code for the hierarchical subsystem, the code contains only the `FUNCTION_BLOCK HierarchicalSubsystem` component. There are no additional function blocks for the S1 and S2 subsystems.

```
FUNCTION_BLOCK HierarchicalSubsystem
VAR_INPUT
    ssMethodType: SINT;
    In1: LREAL;
    In2: LREAL;
    In3: UINT;
    In4: LREAL;
END_VAR
VAR_OUTPUT
    Out1: LREAL;
    Out2: LREAL;
END_VAR
VAR
    UnitDelay_DSTATE: LREAL;
    UnitDelay1_DSTATE: LREAL;
    UnitDelay_DSTATE_j: LREAL;
    UnitDelay_DSTATE_a: LREAL;
END_VAR
VAR_TEMP
    rtb_Gain: LREAL;
    rtb_Gain_c: LREAL;
END_VAR
CASE ssMethodType OF
    SS_INITIALIZE:
        (* InitializeConditions for UnitDelay: '<S1>/Unit Delay' *)
        UnitDelay_DSTATE := 0.0;
```

Multiple Function Blocks for Nonvirtual Subsystems

The `plcdemo_hierarchical_subsystem` example contains an atomic subsystem that has two nonvirtual subsystems, S1 and S2. Virtual subsystems have the **Treat as atomic unit** parameter selected. When you generate code for the hierarchical subsystem, that code contains the `FUNCTION_BLOCK HierarchicalSubsystem`, `FUNCTION_BLOCK HierarchicalSubsystem_S1`, and `FUNCTION_BLOCK HierarchicalSubsystem_S2` components.

Function Block for Hierarchical Subsystem

```
FUNCTION_BLOCK HierarchicalSubsystem
VAR_INPUT
    ssMethodType: SINT;
    In1: LREAL;
    In2: LREAL;
    In3: UINT;
    In4: LREAL;
END_VAR
```

Function Block for Hierarchical S1

```
FUNCTION_BLOCK S1
VAR_INPUT
    ssMethodType: SINT;
    U: LREAL;
```

Function Block for Hierarchical S2

```
FUNCTION_BLOCK S2
VAR_INPUT
    ssMethodType: SINT;
    U: LREAL;
```

Control Generated Code Using Subsystem Block Parameters

You can partition generated code using the following Subsystem block parameters on the Code Generation tab. See the Subsystem block documentation for details.

- **Function packaging**
- **Function name options**

Leave the **File name options** set to the default, Auto.

Generating Separate Partitions and Inlining Subsystem Code

Use the **Function packaging** parameter to specify the code format to generate for an atomic (nonvirtual) subsystem. The Simulink PLC Coder software interprets this parameter depending on the setting that you choose:

Setting	Coder Interpretation
Auto	Uses the optimal format based on the type and number of subsystem instances in the model.
Reusable function, Function	Generates a function with arguments that allows the subsystem code to be shared by other instances of it in the model.
Inline	Inlines the subsystem unconditionally.

For example, in the `plcdemo_hierarchical_virtual_subsystem`, you can:

- Inline the S1 subsystem code by setting **Function packaging** to **Inline**. This setting creates one function block for the parent with the S1 subsystem inlined.
- Create a function block for the S2 subsystem by setting **Function packaging** to **Reusable function**, **Auto**, or **Function**. This setting creates two function blocks, one for the parent, one for S2.

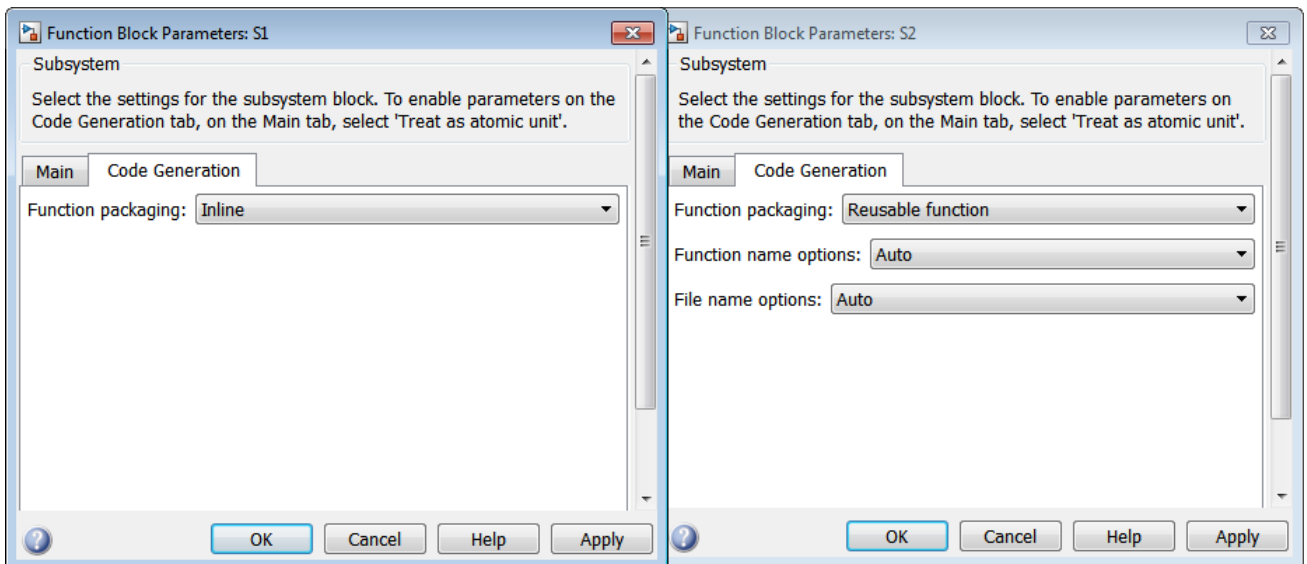

Changing the Name of a Subsystem

You can use the **Function name options** parameter to change the name of a subsystem from the one on the block label. When the Simulink PLC Coder generates software, it uses the string you specify for this parameter as the subsystem name. For example, see `plcdemo_hierarchical_virtual_subsystem`:

- 1** Open the S1 subsystem block parameter dialog box.
- 2** If the **Treat as atomic unit** check box is not yet selected, select it.
- 3** Click the Code Generation tab.
- 4** Set **Function packaging** to Function.
- 5** Set **Function name options** to User specified.
- 6** In the **Function name** field, specify a custom name. For example, type `my_own_subsystem`.

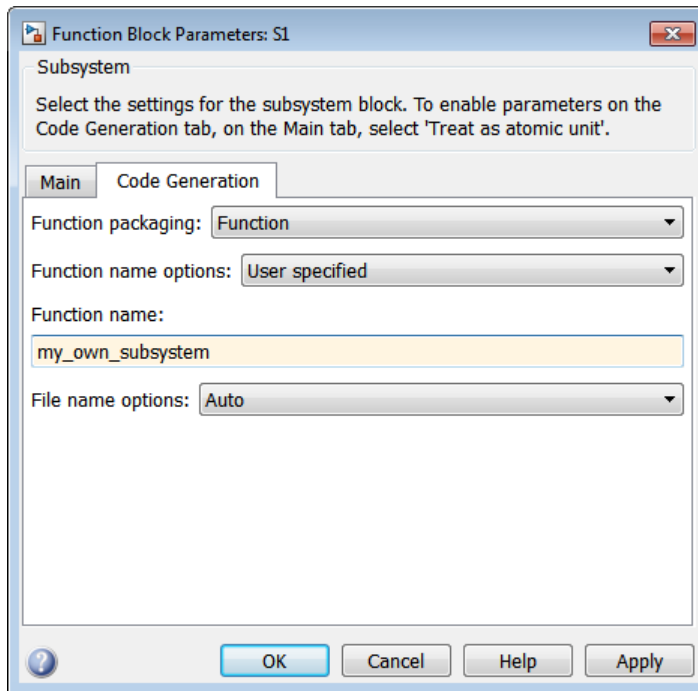

- 7 Save the new settings.
- 8 Generate code for the parent subsystem.
- 9 Observe the renamed function block.

```
FUNCTION_BLOCK my_own_subsystem
VAR_INPUT
    ssMethodType: SINT;
    U: LREAL;
END_VAR
```

Integrating Externally Defined Symbols

- “Integrate Externally Defined Symbols” on page 7-2
- “Integrate Custom Function Block in Generated Code” on page 7-3

Integrate Externally Defined Symbols

The coder allows you to suppress symbol definitions in the generated code. This suppression allows you to integrate a custom element, such as user defined function blocks, function blocks, data types, and named global variable and constants, in place of one generated from a Simulink subsystem. You must then provide these definitions when importing the code into the target IDE. You must:

- Define the custom element in the subsystem for which you want to generate code.
- Name the custom element.
- In the Configuration Parameters dialog box, add the name of the custom element to **PLC Code Generation > Symbols > Externally Defined Symbols** in the Configuration Parameters dialog box.
- Generate code.

For a description of how to integrate a custom function block, see “Integrate Custom Function Block in Generated Code” on page 7-3. For a description of the **Externally Defined Symbols** parameter, see “Externally Defined Symbols” on page 12-25.

Integrate Custom Function Block in Generated Code

To integrate a custom function block, `ExternallyDefinedBlock`, this procedure uses the example `plcdemo_external_symbols`.

- 1** In a Simulink model, add a MATLAB Function block.
- 2** Double-click the MATLAB Function block.
- 3** In the MATLAB editor, minimally define inputs, outputs, and stubs. For example:

```
function Y = fcn(U,V)
% Stub behavior for simulation. This block
% is replaced during code generation
Y = U + V;
```

- 4** Change the MATLAB Function block name to `ExternallyDefinedBlock`.
- 5** Create a subsystem from this MATLAB Function block.
- 6** Complete the model to look like `plcdemo_external_symbols`.

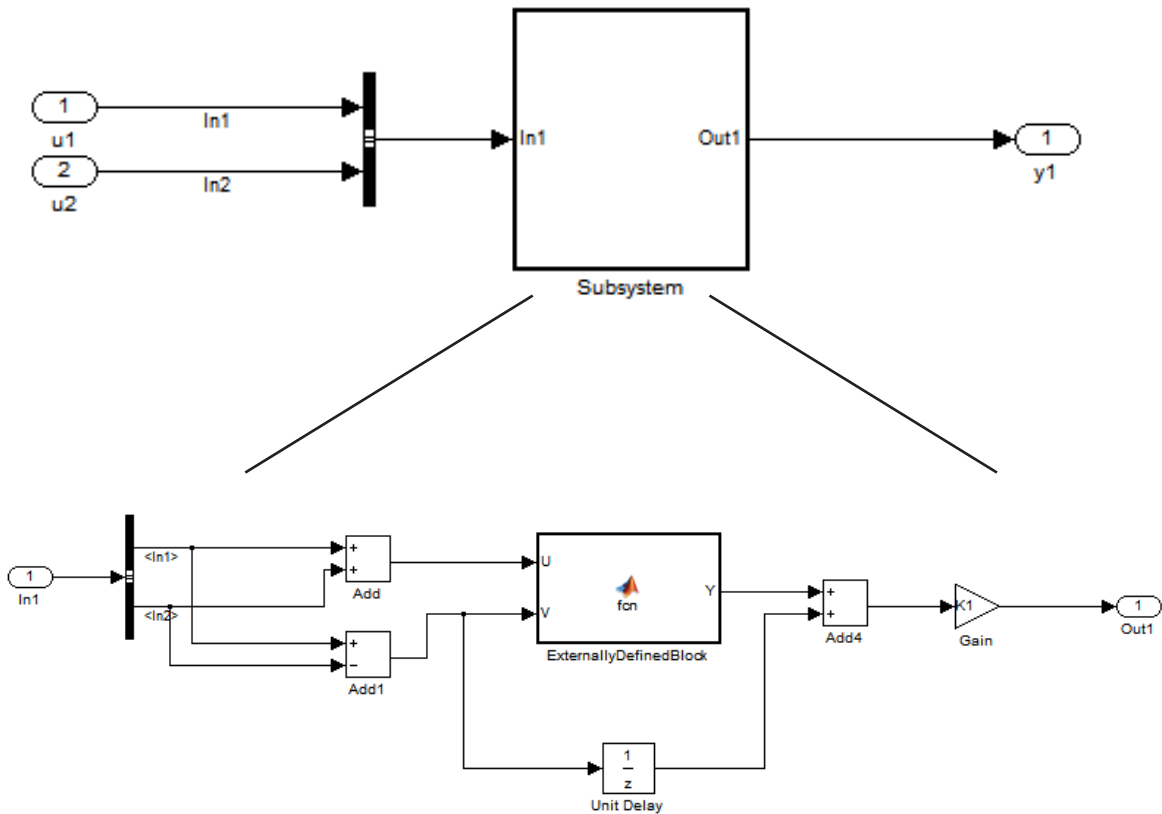

7 Open the Configuration Parameters dialog box for the model.

8 Add `ExternallyDefinedBlock` to **PLC Code Generation > Symbols > Externally Defined Symbols**.

9 The `plcdemo_external_symbols` model also suppresses `K1` and `InBus`. Add these symbol names to the **Externally Defined Symbols** field, separated by spaces. For other settings, see the `plcdemo_external_symbols` model.

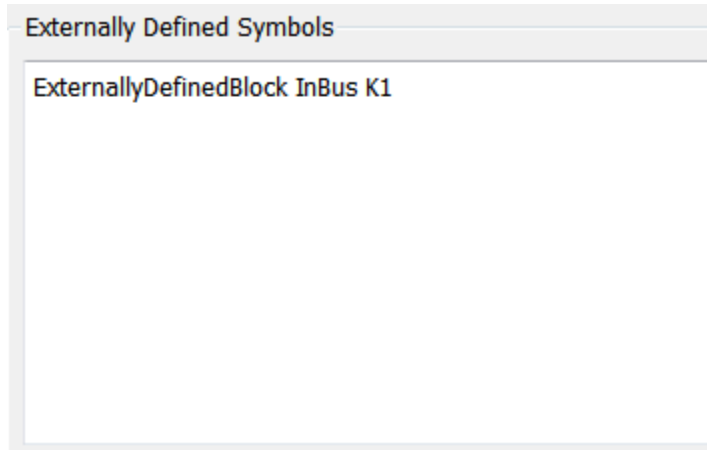

- 10** Save and close your new model. For example, save it as `plcdemo_external_symbols_mine`.
- 11** Generate code for the model.
- 12** In the generated code, look for instances of `ExternallyDefinedBlock`.

The reference of `ExternallyDefinedBlock` is:

```
VAR
    UnitDelay_DSTATE: LREAL;
    i0_ExternallyDefinedBlock: ExternallyDefinedBlock;
END_VAR
```

The omission of `ExternallyDefinedBlock` is:

```
(* MATLAB Function: '<S1>/ExternallyDefinedBlock' *)
i0_ExternallyDefinedBlock(U := rtb_Add, V := rtb_Add1);
rtb_Y := i0_ExternallyDefinedBlock.Y;
```

IDE-Specific Considerations

- “Rockwell Automation RSLogix Considerations” on page 8-2
- “Siemens SIMATIC STEP 7 Considerations” on page 8-4

Rockwell Automation RSLogix Considerations

This topic describes the considerations to remember for this target IDE platform.

Add-On Instruction and Function Blocks

The structured text concept of function block exists for Rockwell Automation RSLogix target IDEs as an Add-On instruction (AOI). The Simulink PLC Coder software generates AOIs for Add-On instruction format, not FUNCTION_BLOCK.

Double-Precision Data Types

The Rockwell Automation RSLogix target IDE does not support double-precision data types. At code generation, the Simulink PLC Coder converts this data type to single-precision data types in generated code.

Note Design your model to use single-precision data type (single) as much as possible instead of double-precision data type (double). If you must use doubles in your model, note that the numerical results produced by the generated structured text might differ from Simulink results. This difference is due to double-single conversion in the generated code.

Unsigned Integer Data Types

The Rockwell Automation RSLogix target IDE does not support unsigned integer data types. At code generation, the Simulink PLC Coder converts this data type to signed integer data types in generated code.

Note Design your model to use signed integer data types (int8, int16, int32) as much as possible instead of unsigned integer data types (uint8, uint16, uint32). Doing so avoids overflow issues that unsigned-to-signed integer conversions can cause in the generated code.

Unsigned Fixed-Point Data Types

In the generated code, Simulink PLC Coder converts fixed-point data types to target IDE integer data types. Because the Rockwell Automation RSLogix target IDE does not support unsigned integer data types, do not use unsigned fixed-point data types in the model. See “Fixed-Point Data Type Limitations” on page 10-3 for coder limitations for fixed-point data type support.

Enumerated Data Types

The Rockwell Automation RSLogix target IDE does not support enumerated data types. At code generation, the Simulink PLC Coder converts this data type to 32-bit signed integer data type in generated code.

Siemens SIMATIC STEP 7 Considerations

This topic describes the considerations to remember for this target IDE platform.

Double-Precision Floating-Point Data Types

The Siemens SIMATIC STEP 7 target IDE does not support double-precision floating-point data types. At code generation, the Simulink PLC Coder converts this data type to single-precision real data types in generated code.

Note Design your model to use single-precision floating-point data type (single) as much as possible instead of double-precision floating-point data type (double). If you must use double-precision floating-point data types in your model, the numerical results produced by the generated structured text might differ from Simulink results. Design your model so that the possible precision loss of numerical results of the generated code does not change the expected semantics of the model.

int8 and Unsigned Integer Types

The Siemens SIMATIC STEP 7 SCL language does not support int8 and unsigned integer data types. At code generation, the Simulink PLC Coder converts int8 and unsigned integer data types to int16 or int32 in generated code.

Note Design your model to use int16 and int32 data types as much as possible instead of int8 or unsigned integer data types. If you must use int8 or unsigned integers, the numerical results produced by the generated structured text might differ from Simulink results. Design your model so that effects of integer data type conversion of the generated code do not change the expected semantics of the model.

Unsigned Fixed-Point Data Types

In the generated code, Simulink PLC Coder converts fixed-point data types to target IDE integer data types. Because the Siemens SIMATIC STEP 7

target IDE does not support unsigned integer data types, do not use unsigned fixed-point data types in the model. See “Fixed-Point Data Type Limitations” on page 10-3 for coder limitations for fixed-point data type support.

Enumerated Data Types

The Siemens SIMATIC STEP 7 target IDE does not support enumerated data types. At code generation, the Siemens SIMATIC STEP 7 converts this data type to 16-bit signed integer data type in generated code.

Supported Simulink and Stateflow Blocks

- “Simulink Blocks” on page 9-2
- “Stateflow Blocks” on page 9-12

Simulink Blocks

To access a Simulink library of blocks that the Simulink PLC Coder software supports, in the MATLAB Command Window, type `plclib`.

Additional Math & Discrete/Additional Discrete

Transfer Fcn Direct Form II

Transfer Fcn Direct Form II Time Varying

Unit Delay Enabled

Unit Delay Enabled External IC

Unit Delay Enabled Resettable

Unit Delay Enabled Resettable External IC

Unit Delay External IC

Unit Delay Resettable

Unit Delay Resettable External IC

Unit Delay With Preview Enabled

Unit Delay With Preview Enabled Resettable

Unit Delay With Preview Enabled Resettable External RV

Unit Delay With Preview Resettable

Unit Delay With Preview Resettable External RV

Commonly Used Blocks

Inport

Bus Creator

Bus Selector

Constant

Data Type Conversion

Demux

Discrete-Time Integrator

Gain

Ground

Logical Operator

Mux

Product

Relational Operator

Saturation

Scope

Subsystem

Inport

Outport

Sum

Switch

Terminator

Unit Delay

Discontinuities

Coulomb and Viscous Friction

Dead Zone Dynamic

Rate Limiter

Rate Limiter Dynamic

Relay

Saturation

Saturation Dynamic

Wrap To Zero

Discrete

Difference

Discrete Transfer Fcn

Discrete Derivative

Discrete FIR Filter

Discrete Filter

PID Controller

PID Controller (2 DOF)

Discrete State-Space

Discrete-Time Integrator

Integer Delay

Memory

Tapped Delay

Transfer Fcn First Order

Transfer Fcn Lead or Lag

Transfer Fcn Real Zero

Unit Delay

Zero-Order Hold

Logic and Bit Operations

Bit Clear

Bit Set

Bitwise Operator

Compare To Constant

Compare To Zero

Detect Change

Detect Decrease

Detect Increase

Detect Fall Negative

Detect Fall Nonpositive

Detect Rise Nonnegative

Detect Rise Positive

Extract Bits

Interval Test

Interval Test Dynamic

Logical Operator

Shift Arithmetic

Lookup Tables

Dynamic-Lookup

Interpolation Using Prelookup

PreLookup

n-D Lookup Table

Math Operations

Abs

Add

Assignment

Bias

Divide

Dot Product

Gain

Math Function

Matrix Concatenate

MinMax

MinMax Running Resettable

Permute Dimensions

Polynomial

Product

Product of Elements

Reciprocal Sqrt

Reshape

Rounding Function

Sign

Slider Gain

Sqrt

Squeeze

Subtract

Sum

Sum of Elements

Trigonometric Function

Unary Minus

Vector Concatenate

Model Verification

Assertion

Check Discrete Gradient

Check Dynamic Gap

Check Dynamic Range

Check Static Gap

Check Static Range

Check Dynamic Lower Bound

Check Dynamic Upper Bound

Check Input Resolution

Check Static Lower Bound

Check Static Upper Bound

Model-Wide Utilities

DocBlock

Model Info

Ports & Subsystems

Atomic Subsystem

CodeReuse Subsystem

Enabled Subsystem

Enable

Function-Call Subsystem

Subsystem

Inport

Outport

Signal Attributes

Data Type Conversion

Data Type Duplicate

Signal Conversion

Signal Routing

Bus Assignment

Bus Creator

Bus Selector

Demux

From

Goto

Goto Tag Visibility

Index Vector

Multiport Switch

Mux

Selector

Sinks

Display

Floating Scope

Scope

Stop Simulation

Terminator

To File

To Workspace

XY Graph

Sources

Constant

Counter Free-Running

Counter Limited

Enumerated Constant

Ground

Pulse Generator

Repeating Sequence Interpolated

Repeating Sequence Stair

User-Defined Functions

MATLAB Function

Fcn

Stateflow Blocks

The code supports the following Stateflow blocks.

Stateflow

C Chart

MATLAB Chart

State Transition Table

Truth Table

Limitations

- “Coder Limitations” on page 10-2
- “Block Restrictions” on page 10-6

Coder Limitations

In this section...
“Current Limitations” on page 10-2
“Fixed-Point Data Type Limitations” on page 10-3
“Permanent Limitations” on page 10-5

Current Limitations

The Simulink PLC Coder software does not support the following Simulink semantics:

- Complex data types
- Model reference
- Global data store memory (DSM)
- Absolute time temporal logic in Stateflow charts

Note Absolute time temporal logic is supported for only the Rockwell Automation RSLogix 5000 IDE.

- Stateflow machine-parented data and events
- Exported graphical functions in Stateflow charts
- Limited support for math functions. The coder does not support the following functions: `tanh`, `cosh`, `sinh`, `rand`.
- Merge block
- Multi-rate models
- Signal and state storage classes
- Virtual buses at the input ports of the top-level Atomic Subsystem block.
- For Each Subsystem block
- Variable-size signals

- Nonfinite data, for example NaN or Inf.

Fixed-Point Data Type Limitations

Simulink PLC Coder software supports the fixed-point data type. To generate code for fixed-point data types, configure block and model parameters as described in this topic.

Note If you do not configure the blocks and models as directed, the generated structured text might:

- Not compile.
 - Compile, but return results that differ from the simulation results.
-

Block Parameters

Properly configure block parameters:

- 1** If the block in the subsystem has a **Signal Attributes** tab, navigate to that tab.
- 2** For the **Integer rounding mode** parameter, select Round.
- 3** Clear the **Saturate on integer overflow** check box.
- 4** For the **Output data type** parameter, select a fixed-point data type.
- 5** Click the **Data Type Assistant** button.
- 6** For the Word length parameter, enter 8, 16, or 32.
- 7** For the **Mode** parameter, select Fixed point.
- 8** For the **Scaling** parameter, select Binary point.

Output minimum:
 Output maximum:

Output data type: fixdt(1,16,0) <<

Data Type Assistant

Mode: Fixed point Signedness: Signed Word length:

Scaling: Binary point Fraction length:

Data type override: Inherit Calculate Best-Precision Scaling

[Fixed-point details](#)

Lock output data type setting against changes by the fixed-point tools

Integer rounding mode: Round

Saturate on integer overflow

9 Click **OK**.

Be sure to edit the model configuration parameters (see “Model Configuration Parameters” on page 10-4).

Model Configuration Parameters

Properly configure model configuration parameters:

- 1 In model Configuration Parameters dialog box, click the Hardware Implementation node.
- 2 For the **Device vendor** parameter, select Generic.
- 3 For the **Device type**, select Custom.
- 4 For the **Signed integer division rounds to**, select Zero.
- 5 For the **Number of bits**, set **char** to 16.

Embedded hardware (simulation and code generation)

Device vendor: Device type:

Number of bits

char:	<input type="text" value="16"/>	short:	<input type="text" value="16"/>	int:	<input type="text" value="32"/>
long:	<input type="text" value="32"/>	float:	<input type="text" value="32"/>	double:	<input type="text" value="64"/>
native:	<input type="text" value="32"/>	pointer:	<input type="text" value="32"/>		

Largest atomic size

integer:

floating-point:

Byte ordering: Signed integer division rounds to:

Shift right on a signed integer as arithmetic shift

Emulation hardware (code generation only)

None

Permanent Limitations

The structured text language has inherent restrictions. As a result, the Simulink PLC Coder software has the following restrictions:

- The Simulink PLC Coder software supports generating code only for atomic subsystems.
- No blocks that require continuous time semantics. This restriction includes continuous integrators, zero-crossing blocks, physical modeling blocks, and so on.
- No pointer data types.
- No recursion (including recursive events).

Block Restrictions

In this section...

“Simulink Block Support Exceptions” on page 10-6

“Stateflow Chart Exceptions” on page 10-6

“Reciprocal Sqrt Block” on page 10-7

“Lookup Table Blocks” on page 10-7

Simulink Block Support Exceptions

The Simulink PLC Coder software supports the `plc1b` blocks with the following exceptions. Also, see “Coder Limitations” on page 10-2 for a list of limitations of the software.

If you get unsupported fixed-point type messages during code generation, update the block parameter. Open the block parameter dialog box. Navigate to the **Signal Attributes** and **Parameter Attributes** tabs. Check that the **Output data type** and **Parameter data type** parameters are not **Inherit: Inherit via internal rule**. Set these parameters to either **Inherit: Same as input** or a desired non-fixed-point data type, such as `double` or `int8`.

Stateflow Chart Exceptions

If you receive a message about consistency between the original subsystem and the S-function generated from the subsystem build, and the model contains a Stateflow chart that contains one or more Simulink functions, use the following procedure to address the issue:

- 1 Open the model and double-click the Stateflow chart that causes the issue.

The chart Stateflow Editor dialog box is displayed.

- 2 Right-click in this dialog box.

- 3 In the context-sensitive menu, select **Properties**.

The Chart dialog box is displayed.

4 In the Chart dialog box, navigate to the **States When Enabling** parameter and select **Held**.

5 Click **Apply** and **OK** and save the model.

Reciprocal Sqrt Block

The Simulink PLC Coder software does not support the Simulink Reciprocal Sqrt block `signedSqrt` and `rSqrt` functions.

Lookup Table Blocks

Simulink PLC Coder has limited support for lookup table blocks. The coder does not support:

- Number of dimensions greater than 2
- Cubic spline interpolation method
- Begin index search using a previous index mode
- Cubic spline extrapolation method

Note The Simulink PLC Coder software does not support the Simulink Lookup Table Dynamic block. For your convenience, the `plib/Simulink/Lookup Tables` library contains an implementation of a dynamic table lookup block using the `Prelookup` and `Interpolation Using Prelookup` blocks.

Functions — Alphabetical List

plccoderdemos

Purpose	Product examples
Syntax	<code>plccoderdemos</code>
Description	<code>plccoderdemos</code> displays the Simulink PLC Coder examples.
Examples	Display Simulink PLC Coder examples. <code>plccoderdemos</code>
See Also	<code>plcopenconfigset</code>

Purpose	Manage user preferences
Syntax	<pre>plccoderpref plccoderpref('plctargetide') plccoderpref('plctargetide', preference_value) plccoderpref('plctargetide', 'default') plccoderpref('plctargetidepaths') plccoderpref('plctargetidepaths', 'default')</pre>
Description	<p>plccoderpref displays the current set of user preferences, including the default target IDE.</p> <p>plccoderpref('plctargetide') returns the current default target IDE. This default can be the target IDE set previously, or the factory default. The factory default is 'codesys23'.</p> <p>plccoderpref('plctargetide', preference_value) sets the default target IDE to the one that you specify in preference_value. This command sets the preference_value to persist as the default target IDE for all future MATLAB sessions.</p> <p>plccoderpref('plctargetide', 'default') sets the default target IDE to the factory default target IDE ('codesys23').</p> <p>plccoderpref('plctargetidepaths') returns a 1-by-1 structure of the installation paths of all supported target IDEs.</p> <p>plccoderpref('plctargetidepaths', 'default') sets the contents of the 1-by-1 structure of the installation paths to the default values.</p>
Tips	Use the Simulink Configuration Parameters dialog box to change the installation path of a target IDE (Target IDE Path).
Input Arguments	<p>plctargetide</p> <p>String directive that specifies the default target IDE.</p>

Value	Description
codesys23	3S-Smart Software Solutions CoDeSys Version 2.3 (default) target IDE
codesys33	3S-Smart Software Solutions CoDeSys Version 3.3 target IDE
brautomation30	B&R Automation Studio 3.0 target IDE
twincat211	Beckhoff TwinCAT 2.11 target IDE
multiprog50	KW-Software MULTIPROG 5.0 target IDE
pcworx60	Phoenix Contact PC WORX 6.0
rslogix5000	Rockwell Automation RSLogix 5000 Series target IDE for AOI format
rslogix5000_routine	Rockwell Automation RSLogix 5000 Series target IDE for routine format
step7	Siemens SIMATIC STEP 7 Version 5 target IDE
plcopen	PLCopen XML target IDE
generic	Generic target IDE

Default: codesys23

plctargetidepaths

String that specifies the target IDE installation path. Contains a 1-by-1 structure of the installation paths of all supported target IDEs.

```
codesys23: 'C:\Program Files\3S Software'  
codesys33: 'C:\Program Files\3S CoDeSys'  
rslogix5000: 'C:\Program Files\Rockwell Software'  
rslogix5000_routine: 'C:\Program Files\Rockwell Software'  
brautomation30: 'C:\Program Files\BrAutomation'
```



```

multiprog50: 'C:\Program Files\KW-Software\MULTIPROG 5.0'
pcworx60: 'C:\Program Files\Phoenix Contact\Software Suite 150'
step7: 'C:\Program Files\Siemens'
plcopen: ''
twincat211: 'C:\TwinCAT'
generic: ''

```

default

String that sets your preferences to the factory default.

Examples

Return the current default target IDE.

```
plccoderpref('plctargetide')
```

Set rslogix5000 as the new default target IDE.

```
plccoderpref('plctargetide', 'rslogix5000')
```

Assume that you have previously changed the installation path of the CoDeSys 2.3 target IDE. Return the current target IDE installation paths.

```

codesys23: 'C:\Program Files2\3S-Software\CoDeSys\v2.3'
codesys33: 'C:\Program Files\3S CoDeSys'
rslogix5000: 'C:\Program Files\Rockwell Software'

rslogix5000_routine: 'C:\Program Files\Rockwell Software'
brautomation30: 'C:\Program Files\BrAutomation'
multiprog50: 'C:\Program Files\KW-Software\MULTIPROG 5.0'
pcworx60: 'C:\Program Files\Phoenix Contact\Software Suite 150'
step7: 'C:\Program Files\Siemens'
plcopen: ''
twincat211: 'C:\TwinCAT'
generic: ''

```

Set the installation path of all the target IDEs, including CoDeSys 2.3, to factory default.

```
» plccoderpref('plctargetidepaths','default')
```

```
ans =
```

```
    codesys23: 'C:\Program Files\3S Software'  
    codesys33: 'C:\Program Files\3S CoDeSys'  
    rslogix5000: 'C:\Program Files\Rockwell Software'  
rslogix5000_routine: 'C:\Program Files\Rockwell Software'  
    brautomation30: 'C:\Program Files\BrAutomation'  
    multiprog50: 'C:\Program Files\KW-Software\MULTIPROG 5.0'  
    pcworx60: 'C:\Program Files\Phoenix Contact\Software Suite 150'  
    step7: 'C:\Program Files\Siemens'  
    plcopen: ''  
    twincat211: 'C:\TwinCAT'  
    generic: ''
```

Purpose Generate structured text for subsystem

Syntax `generatedfiles = plcgeneratecode(subsystem)`

Description `generatedfiles = plcgeneratecode(subsystem)` generates structured text for the specified atomic subsystem in a model. *subsystem* is the fully qualified path name of the atomic subsystem. *generatedfiles* is a cell array of the generated file names. You must first load or start the model.

Examples Generate code for the subsystem, `plcdemo_simple_subsystem/SimpleSubsystem`.

```
plcdemo_simple_subsystem
generatedfiles = plcgeneratecode('plcdemo_simple_subsystem/SimpleSubsystem')
```

See Also `plcopenconfigset`

plcopenconfigset

Purpose Open Configuration Parameters dialog box for subsystem

Syntax `plcopenconfigset(subsystem)`

Description `plcopenconfigset(subsystem)` opens the Configuration Parameters dialog box for the specified atomic subsystem in the model. *subsystem* is the fully qualified path name of the atomic subsystem.

Examples Open the Configuration Parameters dialog box for the subsystem, `plcdemo_simple_subsystem/SimpleSubsystem`.

```
plcdemo_simple_subsystem
plcopenconfigset('plcdemo_simple_subsystem/SimpleSubsystem')
```

See Also `plcgeneratecode`

Configuration Parameters for Simulink PLC Coder Models

- “PLC Coder: General” on page 12-2
- “PLC Coder: Comments” on page 12-10
- “PLC Coder: Optimization” on page 12-15
- “PLC Coder: Symbols” on page 12-20
- “PLC Coder: Report” on page 12-26

PLC Coder: General

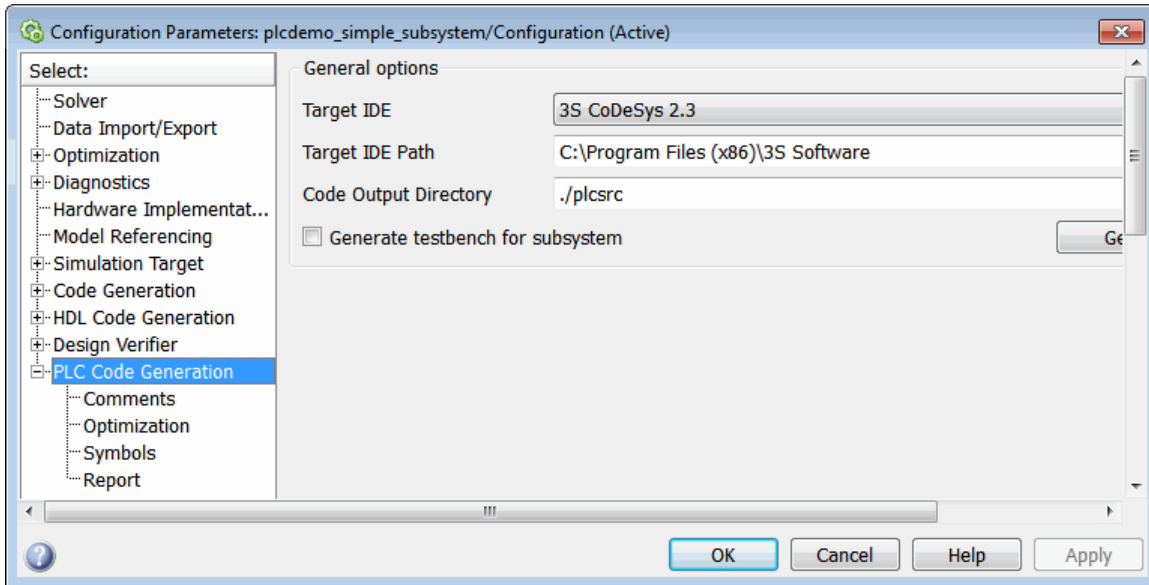

In this section...

“PLC Coder: General Tab Overview” on page 12-3

“Target IDE” on page 12-4

“Target IDE Path” on page 12-6

“Code Output Directory” on page 12-8

“Generate testbench for subsystem” on page 12-9

PLC Coder: General Tab Overview

Set up general information about generating structured text code to download to target PLC IDEs.

Configuration

To enable the Simulink PLC Coder options pane, you must:

- 1 Create a model.
- 2 Add either an Atomic Subsystem block, or a Subsystem block for which you have selected the **Treat as atomic unit** check box.
- 3 Right-click the subsystem block and select **PLC Code > Options**.

Tip

In addition to configuring parameters for the Simulink PLC Coder model, you can also use this dialog box to generate structured text code and test bench code for the Subsystem block.

See Also

“Prepare Model for Structured Text Generation” on page 1-11

“Generate Structured Text from the Model Window” on page 1-19

Target IDE

Select the target IDE in which to generate code.

Settings

Default: 3S CoDeSys 2.3

3S CoDeSys 2.3

Generates structured text (IEC 61131) code for 3S-Smart Software Solutions CoDeSys Version 2.3.

3S CoDeSys 3.3

Generates structured text code in PLCopen XML for 3S-Smart Software Solutions CoDeSys Version 3.3.

B&R Automation Studio 3.0

Generates structured text code for B&R Automation Studio 3.0.

Beckhoff TwinCAT 2.11

Generates structured text code for Beckhoff TwinCAT 2.11 software.

KW-Software MULTIPROG 5.0

Generates structured text code in PLCopen XML for KW-Software MULTIPROG® 5.0.

Phoenix Contact PC WORX 6.0

Generates structured text code in PLCopen XML for Phoenix Contact PC WORX 6.0.

Rockwell RSLogix 5000: AOI

Generates structured text code for Rockwell Automation RSLogix 5000 using Add-On Instruction (AOI) constructs.

Rockwell RSLogix 5000: Routine

Generates structured text code for Rockwell Automation RSLogix 5000 routine constructs.

Siemens SIMATIC Step 7 5.4

Generates structured text code for Siemens SIMATIC STEP 7 5.4.

Generic

Generates a pure structured text file. If the target IDE that you want is not available for the Simulink PLC Coder product, consider generating and downloading a generic structured text file.

PLCopen XML

Generates structured text code formatted using PLCopen XML standard.

Tip

- Rockwell Automation RSLogix 5000 routines represent the model hierarchy using hierarchical user-defined types (UDTs). UDT types preserve model hierarchy in the generated code.
- The coder generates code for reusable subsystems as separate routine instances. These subsystems access instance data in program tag fields.

Command-Line Information

Parameter: PLC_TargetIDE

Type: string

Value: 'codesys23' | 'codesys33' | 'rslogix5000' | 'rslogix5000_routine' | 'brautomation30' | 'multiprog50' | 'pcworx60' | 'step7' | 'plcopen' | 'twincat211' | 'generic'

Default: 'codesys23'

See Also

“Generate Structured Text from the Model Window” on page 1-19

Target IDE Path

Enter target IDE installation path. The listed path is the factory default for the **Target IDE** entry.

Settings

Default: C:\Program Files\3S Software

C:\Program Files\3S Software

Factory default installation path for 3S-Smart Software Solutions CoDeSys software Version 2.3.

C:\Program Files\3S CoDeSys

Factory default installation path for 3S-Smart Software Solutions CoDeSys software Version 3.3..

C:\Program Files\BrAutomation

Factory default installation path for B&R Automation Studio 3.0 software.

C:\TwinCAT

Factory default installation path for Beckhoff TwinCAT 2.11 software.

C:\Program Files\KW-Software\MULTIPROG 5.0

Factory default installation path for KW-Software MULTIPROG 5.0 software.

C:\Program Files\Phoenix Contact\Software Suite 150

Factory default installation path for Phoenix Contact PC WORX 6.0 software.

C:\Program Files\Rockwell Software

Factory default installation path for Rockwell Automation RSLogix 5000 software.

C:\Program Files\Siemens

Factory default installation path for Siemens SIMATIC STEP 7 5.4 software.

Tip

- The value of this parameter changes when you change the **Target IDE** value.

- If you right-click the Subsystem block, the **PLC Code > Generate and Import Code for Subsystem** command uses this value to import generated code.
- If your target IDE installation is standard, do not edit this parameter. Leave it as the default value.
- If your target IDE installation is nonstandard, edit this value to specify the actual installation path.
- If you change the path and click **Apply**, the changed path remains for that target IDE for other models and between MATLAB sessions. To reinstate the factory default, use the command:

```
plccoderpref('plctargetidepaths','default')
```

Command-Line Information

See `plccoderpref`.

See Also

“Import Structured Text Code Automatically” on page 1-31

Code Output Directory

Enter a path to the target folder into which code is generated.

Settings

Default: plcsrc subfolder in your working folder

Command-Line Information

Parameter: PLC_OutputDir

Type: string

Value: './plcsrc'

Default: './plcsrc'

See Also

“Generate Structured Text from the Model Window” on page 1-19

Generate testbench for subsystem

Specify the generation of test bench code for the subsystem.

Settings

Default: off



On

Enables generation of test bench code for subsystem.



Disables generation of test bench code for subsystems.

Tips

If you right-click the Subsystem block and choose **PLC Code > Generate and Import Code for Subsystem**, the software also generates the test bench for the subsystem, regardless of the setting of the **Generate testbench for subsystem** check box.

Dependency

This parameter is disabled if your model has absolute time temporal logic.

Note The Simulink PLC Coder software supports absolute time temporal logic in Stateflow charts for the Rockwell Automation RSLogix 5000 IDE.

Command-Line Information

Parameter: PLC_GenerateTestbench

Type: string

Value: 'on' | 'off'

Default: 'off'

See Also

“Generate Structured Text from the Model Window” on page 1-19

PLC Coder: Comments

Overall control	
<input checked="" type="checkbox"/>	Include comments
<input checked="" type="checkbox"/>	Include block description
Auto generated comments	
<input checked="" type="checkbox"/>	Simulink block / Stateflow object comments
<input type="checkbox"/>	Show eliminated blocks

In this section...

“Comments Overview” on page 12-11

“Include comments” on page 12-11

“Include block description” on page 12-12

“Simulink block / Stateflow object comments” on page 12-13

“Show eliminated blocks” on page 12-14

Comments Overview

Control the comments that the Simulink PLC Coder software automatically creates and inserts into the generated code.

See Also

“Generate Structured Text from the Model Window” on page 1-19

Include comments

Specify which comments are in generated files.

Settings

Default: on



On

Places comments in the generated files based on the selections in the **Auto generated comments** pane.



Off

Omits comments from the generated files.

Command-Line Information

Parameter: PLC_RTWGenerateComments

Type: string

Value: 'on' | 'off'

Default: 'on'

See Also

“Generate Structured Text from the Model Window” on page 1-19

Include block description

Specify which block description comments are in generated files.

Settings

Default: on



On

Places comments in the generated files based on the contents of the block properties **General** tab.



Off

Omits block descriptions from the generated files.

Command-Line Information

Parameter: PLC_RTWGenerateDescriptions

Type: string

Value: 'on' | 'off'

Default: 'on'

See Also

“Generate Structured Text from the Model Window” on page 1-19

Simulink block / Stateflow object comments

Specify whether to insert Simulink block and Stateflow object comments.

Settings

Default: on



On

Inserts automatically generated comments that describe block code and objects. The comments precede that code in the generated file.



Off

Suppresses comments.

Command-Line Information

Parameter: PLC_RTWSimulinkBlockComments

Type: string

Value: 'on' | 'off'

Default: 'on'

See Also

“Generate Structured Text from the Model Window” on page 1-19

Show eliminated blocks

Specify whether to insert eliminated block comments.

Settings

Default: off



On

Inserts statements in the generated code from blocks eliminated as the result of optimizations (such as parameter inlining).



Off

Suppresses statements.

Command-Line Information

Parameter: PLC_RTWSHOWEliminatedStatement

Type: string

Value: 'on' | 'off'

Default: 'off'

See Also

“Generate Structured Text from the Model Window” on page 1-19

PLC Coder: Optimization

Optimization options

- Signal storage reuse
- Remove code from floating-point to integer conversions that wraps out-of-range values

Loop unrolling threshold:

In this section...

“Optimization Overview” on page 12-15

“Signal storage reuse” on page 12-16

“Remove code from floating-point to integer conversions that wraps out-of-range values” on page 12-18

“Loop unrolling threshold” on page 12-19

Optimization Overview

Select the code generation optimization settings.

See Also

“Generate Structured Text from the Model Window” on page 1-19

Signal storage reuse

Reuse signal memory.

Settings

Default: on



On

Simulink PLC Coder software reuses memory buffers allocated to store block input and output signals, reducing the memory requirement of your real-time program.



Off

Simulink PLC Coder software allocates a separate memory buffer for each block's outputs. This allocation makes all block outputs global and unique, which in many cases significantly increases RAM and ROM usage.

Tips

- This option applies only to signals with storage class **Auto**.
- Signal storage reuse can occur among only signals that have the same data type.
- Clearing this option can substantially increase the amount of memory required to simulate large models.
- Clear this option if you need to:
 - Debug a C-MEX S-function.
 - Use a Floating Scope or a Display block with the **Floating display** option selected to inspect signals in a model that you are debugging.
- If **Signal storage reuse** is enabled and you attempt to use a Floating Scope or floating Display block to display a signal whose buffer has been reused, Simulink PLC Coder software opens an error dialog.

Command-Line Information

Parameter:PLC_PLCEnableVarReuse

Type: string
Value: 'on' | 'off'
Default: 'on'

See Also

“Generate Structured Text from the Model Window” on page 1-19

Remove code from floating-point to integer conversions that wraps out-of-range values

Enable code removal for efficient casts.

Settings

Default: on



On

Simulink PLC Coder software removes code from floating-point to integer conversions.



Off

Simulink PLC Coder software does not remove code from floating-point to integer conversions.

Tips

Use this parameter to optimize code generation.

Command-Line Information

Parameter: PLC_PLCEnableEfficientCast

Type: string

Value: 'on' | 'off'

Default: 'on'

See Also

“Generate Structured Text from the Model Window” on page 1-19

Loop unrolling threshold

Specify the minimum signal or parameter width for which a for loop is generated.

Settings

Default: 5

Specify the array size at which the code generator begins to use a for loop instead of separate assignment statements to assign values to the elements of a signal or parameter array.

When there are perfectly nested loops, the code generator uses a for loop if the product of the loop counts for all loops in the perfect loop nest is greater than or equal to the threshold.

Command-Line Information

Parameter: PLC_RollThreshold

Type: string

Value: any valid value

Default: '5'

See Also

“Generate Structured Text from the Model Window” on page 1-19

PLC Coder: Symbols

Auto-generated identifier naming rules
Maximum identifier length: <input type="text" value="31"/>
Reserved names
<input type="checkbox"/> Use the same reserved names as Simulation Target
Reserved names:
<div style="border: 1px solid gray; height: 150px;"></div>
Externally Defined Symbols
<div style="border: 1px solid gray; height: 150px;"></div>

In this section...

“Symbols Overview” on page 12-21

“Maximum identifier length” on page 12-22

“Use the same reserved names as Simulation Target” on page 12-23

“Reserved names” on page 12-24

“Externally Defined Symbols” on page 12-25

Symbols Overview

Select the automatically generated identifier naming rules.

See Also

“Generate Structured Text from the Model Window” on page 1-19

Maximum identifier length

Specify the maximum number of characters in generated function, type definition, and variable names.

Settings

Default: 31

Minimum: 31

Maximum: 256

You can use this parameter to limit the number of characters in function, type definition, and variable names. Many target IDEs have their own restrictions. The Simulink PLC Coder software complies with target IDE limitations.

Command-Line Information

Parameter: PLC_RTWMaxIdLength

Type: int

Value: 31 to 256

Default: 31

See Also

“Generate Structured Text from the Model Window” on page 1-19

Use the same reserved names as Simulation Target

Specify whether to use the same reserved names as those specified in the **Simulation Target > Symbols** pane.

Settings

Default: off



On

Enables using the same reserved names as those specified in the **Simulation Target > Symbols** pane.



Off

Disables using the same reserved names as those specified in the **Simulation Target > Symbols** pane.

Command-Line Information

Parameter: PLC_RTWUseSimReservedNames

Type: string

Value: 'on' | 'off'

Default: 'off'

See Also

“Generate Structured Text from the Model Window” on page 1-19

Reserved names

Enter the names of variables or functions in the generated code that you do not want to be used.

Settings

Default: ()

This action changes the names of variables or functions in the generated code to avoid name conflicts with identifiers in custom code. Reserved names must be shorter than 256 characters.

Tips

- Start each reserved name with a letter or an underscore.
- Each reserved name must contain only letters, numbers, or underscores.
- Separate the reserved names using commas or spaces.

Command-Line Information

Parameter: PLC_RTWReservedNames

Type: string

Value: string

Default: ''

See Also

“Generate Structured Text from the Model Window” on page 1-19

Externally Defined Symbols

Specify the names of identifiers for which you want to suppress definitions.

Settings

Default: ()

This action suppresses the definition of identifiers, such as those for function blocks, variables, constants, and user types in the generated code. This suppression allows the generated code to refer to these identifiers. When you import the generated code into the PLC IDE, you must provide these definitions.

Tips

- Start each name with a letter or an underscore.
- Each name must contain only letters, numbers, or underscores.
- Separate the names using spaces.

Command-Line Information

Parameter: PLC_ExternalDefinedNames

Type: string

Value: string

Default: ''

See Also

- “Generate Structured Text from the Model Window” on page 1-19
- “Integrate Externally Defined Symbols” on page 7-2
- Integrating User Defined Function Blocks, Data Types, and Global Variables into Generated Structured Text

PLC Coder: Report

Code generation report

- Generate traceability report
- Generate model web view

In this section...

“Generate traceability report” on page 12-26

“Generate model Web view” on page 12-27

Generate traceability report

Specify whether to create a code generation report.

Settings

Default: off



On

Creates code generation report as HTML file.



Off

Suppresses creation of code generation report.

Command-Line Information

Parameter: PLC_GenerateReport

Type: string

Value: 'on' | 'off'

Default: 'off'

See Also

“Generate Structured Text from the Model Window” on page 1-19

Generate model Web view

Include the model Web view in the code generation report to navigate between the code and the model within the same window. You can share your model and generated code outside of the MATLAB environment. You need a Simulink Report Generator license to include a Web view of the model in the code generation report.

Settings

Default: Off



On

Include model Web view in the code generation report.



Off

Omit model Web view in the code generation report.

Command-Line Information

Parameter: PLC_GenerateWebView

Type: string

Value: 'on' | 'off'

Default: 'off'

See Also

“Generate Structured Text from the Model Window” on page 1-19

A

- accessing supported blocks 1-6
- atomic subsystems 1-11

B

- B&R Automation Studio® 1-7
 - accessing 1-8
- basic workflow 1-10
- Beckhoff® TwinCAT® 1-7
 - accessing 1-8
- before you start 1-11
- block parameters 6-5

C

- changing name of a subsystem 6-7
- Code generation
 - development process 1-3
- CoDeSys 1-7
 - importing 1-8
- compatibility 1-16
- configuration parameters
 - pane 12-3 12-11 12-15 12-21
 - Create code generation report 12-26
 - Externally Defined Symbols 12-25
 - Generate model Web view 12-27
 - Include block descriptions 12-12
 - Include comments 12-11
 - Loop unrolling threshold 12-19
 - Maximum identifier length: 12-22
 - Output directory 12-8 to 12-9
 - Remove code from floating-point to integer conversions that wraps out-of-range values 12-18
 - Reserved names: 12-24
 - Show eliminated blocks 12-14
 - Signal storage reuse 12-16
 - Simulink block / Stateflow object comments 12-13

- Target IDE 12-4
- Target IDE Path 12-6
- Use the same reserved names as Simulation Target 12-23

- PLC Coder: General 12-2
 - reference 12-1

- configuring parameters to be tunable 5-19
- configuring Simulink® models 1-11
- configuring tunable parameters 5-2

D

- defining tunable parameters in the MATLAB® workspace 5-12 5-17

E

- expected background 1-3
- expected users 1-3

F

- function block 1-4
 - generating multiple for nonvirtual subsystems 6-4
 - generating one for atomic subsystems 6-2
 - generating one for virtual subsystems 6-3
 - partitions 6-2
- functions
 - plccoderdemos 11-2
 - plccoderpref 11-3
 - plcgeneratecode 11-7
 - plcopenconfigset 11-8

G

- generated code
 - controlling with block parameters 6-5
 - mapping MATLAB® Coder™ subsystems to function blocks 2-11
 - mapping reusable code to function blocks 2-5

- mapping Stateflow® enabled and triggered subsystems to function blocks 2-7
- mapping Stateflow® subsystems to function blocks 2-9
- mapping to function blocks 2-3
- partitioning 6-1
- generating and examining structured text code 1-19
- generating and importing structured text 3-5
- generating code 1-19
 - MATLAB® interface 1-24
- generating separate partitions and inlining subsystem code 6-5
- generating structured text code 1-19
- generating test bench code 3-1
- glossary 1-4

I

- IDE platforms
 - supported 1-7
- identifying tunable parameters 5-8
- IEC 61131-3 1-4

K

- KW-Software MULTIPROG®
 - accessing 1-8

L

- limitations 10-1

M

- mapping Simulink® semantics 2-2

N

- nonvirtual subsystems 6-4

P

- partitioning
 - controlling generated code with subsystem block parameters 6-5
 - generated code 6-1
 - multiple function block for nonvirtual subsystems 6-4
 - one function block for atomic subsystems 6-2
 - one function block for virtual subsystems 6-3
- platforms 1-7
- PLC Coder: General
 - configuration parameters 12-2
- plccoderdemos function 11-2
- plccoderpref function 11-3
- plcgeneratecode 1-24
- plcgeneratecode function 11-7
- PLCopen 1-4
- plcopenconfigset 1-24
- plcopenconfigset function 11-8

R

- related products 1-5
- requirements 1-5
- Rockwell Automation® RSLogix™ 1-7
 - accessing 1-9
 - considerations 8-2
 - double-precision data types 8-2
 - enumerated integer data types 8-3
 - unsigned fixed-point data types 8-3
 - unsigned integer data types 8-2

S

- Siemens® SIMATIC® STEP® 7
 - accessing 1-9
 - considerations 8-4
 - double-precision floating-point data types 8-4
 - enumerated integer data types 8-5

- int8 and unsigned integer data types 8-4
- Siemens®SIMATIC®STEP® 7
 - unsigned fixed-point data types 8-4
- Simulink®
 - semantics 2-2
- Simulink® PLC Coder™
 - limitations 10-1
- structured text 1-4
- subsystem block parameters 6-5
- subsystems
 - atomic 1-11
- supported blocks
 - accessing 1-6
- supported IDE platforms 1-7
- system requirements 1-4

T

- target platforms 1-7
- test bench code

- generating 3-1
- Treat as atomic unit 1-11
- tunable parameters
 - about 5-2
 - configuring 5-2
 - identifying 5-8
 - MATLAB® workspace 5-12 5-17

U

- useful terms 1-4

V

- virtual subsystems 6-3

W

- working with generated structured text 3-2